

# GETTING STARTED WITH MINIMED™ 770G CONTINUOUS GLUCOSE MONITORING



## Copyright & trademarks

© 2020 Medtronic. All rights reserved. Medtronic, Medtronic logo and Further, Together are trademarks of Medtronic. <sup>TM\*</sup> Third party brands are trademarks of their respective owners. All other brands are trademarks of a Medtronic company.

Bolus Wizard<sup>TM</sup>, Guardian<sup>TM</sup>, MiniMed<sup>TM</sup>, Mio<sup>TM</sup>, Silhouette<sup>TM</sup>, SmartGuard<sup>TM</sup>, Sure-T<sup>TM</sup>, and Quick-set<sup>TM</sup> are trademarks of Medtronic MiniMed, Inc.

ACCU-CHEK and ACCU-CHEK GUIDE are trademarks of Roche.

## Continuous Glucose Monitoring

- **Getting started with continuous glucose monitoring (CGM)**
  - Section 1: Welcome to CGM ..... 1**
  - Section 2: SG and BG ..... 2**
  - Section 3: Trends ..... 3**
  - Section 4: Personalized alerts ..... 4**
    - Turning the Sensor feature on ..... 5
    - High Setup ..... 5
    - Low Setup ..... 9
    - Snooze ..... 14
    - Changing High or Low Setup ..... 15
    - Alert Silence feature ..... 16
  - Section 5: Pairing your pump and transmitter ..... 17**
  - Section 6: Inserting and starting the sensor ..... 20**
    - Selecting your site ..... 21
    - Inserting your sensor ..... 22
    - Taping your sensor ..... 27
    - Connecting your transmitter ..... 28
    - Checking for proper tape application ..... 30
    - Starting the sensor ..... 30
  - Section 7: Calibration ..... 32**
    - Calibrating the sensor ..... 33
    - Calibration reminder ..... 36
  - Section 8: Reading the sensor display ..... 37**
    - Status icons ..... 37
    - SmartGuard suspend icon ..... 38
    - Sensor status ..... 38
    - Current sensor value ..... 38
    - Sensor graph ..... 38
    - Additional sensor graphs ..... 39

# Contents

<b>Section 9: Sensor alerts and suspend</b> .....	<b>41</b>
Sensor alerts.....	41
SmartGuard suspend features.....	42
Resuming basal insulin.....	43
Manual basal resume .....	43
SmartGuard suspend features unavailable.....	44
<b>Section 10: Charging and storing the Guardian Link (3) transmitter</b> .....	<b>45</b>
<b>Section 11: Traveling by air</b> .....	<b>46</b>
<b>Section 12: X-rays, MRI, or CT scan</b> .....	<b>47</b>

## ■ Training handouts

Quick Reference Guide for Sensor Alerts.....	51
Quick Reference Guide for Using the One-press Serter with Guardian™ Sensor (3) .....	53
Quick Reference Guide for SmartGuard™ Suspend Features.....	57

## Getting started with continuous glucose monitoring (CGM)

### Section 1: Welcome to CGM

Continuous glucose monitoring (CGM) gives you a more complete picture of your glucose control than blood glucose (BG) monitoring alone. Using a sensor allows you to receive up to 288 sensor glucose (SG) readings every 24 hours, filling the gaps between your BG checks. CGM alerts notify you of high and low glucose values. Graphs and trend arrows show the speed and direction your glucose levels are moving.

The MiniMed 770G system with wireless technology includes SmartGuard features which automatically adjust insulin delivery based on SG values. The SmartGuard technology can be used in two modes: Manual Mode or Auto Mode. In this section, you will learn about using CGM and the following SmartGuard suspend features in Manual Mode: SmartGuard Suspend before low and SmartGuard Suspend on low. You will learn about SmartGuard Auto Mode later.

The first step in using CGM is understanding the items included in your CGM system.

Your CGM system includes 3 key items:

#### 1 Transmitter\*

The Guardian Link (3) transmitter connects to the glucose sensor and sends glucose readings to your insulin pump. "GL3" is marked on the transmitter. Only the transmitter marked with "GL3" can communicate with the MiniMed 770G insulin pump.



#### 2 Glucose sensor

The Guardian Sensor (3) measures glucose levels in the body.

#### 3 Insulin pump

The MiniMed 770G insulin pump displays glucose readings.



Other items include: one-press senter, oval tape, charger, and tester.

Always use the components that were sent with the MiniMed 770G insulin pump.

Drawings throughout this document are only generic representations of the system components.

\* The transmitter must be within 1.8 meters (6 feet) of the insulin pump with no obstacles in order to communicate sensor readings.

## Section 2: SG and BG

Your **BG meter** measures glucose levels in your blood. The glucose sensor measures glucose in the fluid surrounding the cells of your tissue called **interstitial fluid**.

Glucose travels between blood and interstitial fluid. Most of the time, glucose travels to your blood first, and then to your interstitial fluid. Because of how glucose moves, **your BG meter readings and SG readings will be close, but will rarely match exactly**. This difference is normal and should be expected.

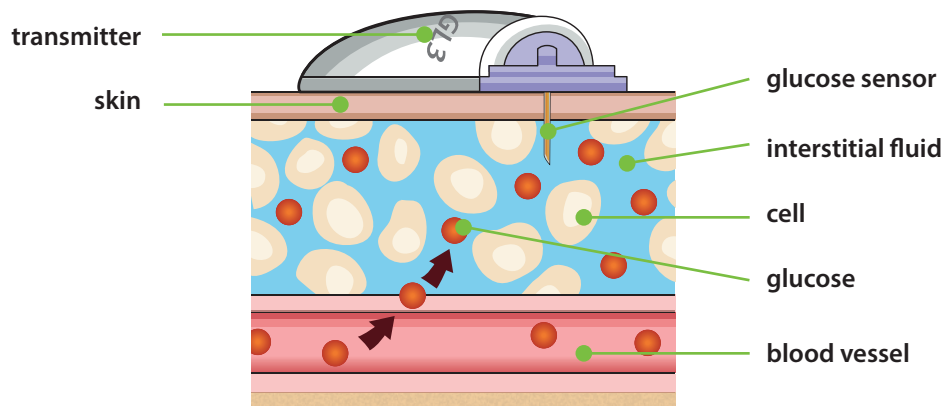

When glucose levels are rising or falling quickly, you should expect to see an even larger difference between your BG meter readings and the SG readings.

Examples of times when this larger difference may occur include:

- after meals or taking a bolus of insulin
- during exercise
- when arrows appear on your pump screen, as explained in *Trends*, on page 3



**WARNING:** SG is not the same as BG. Your SG and BG readings will be close to one another, but will rarely match exactly.

Do not make treatment decisions, such as determining your insulin dose for meals, using the MiniMed 770G system CGM values, as they are not intended to be used to make such treatment decisions. The MiniMed 770G system CGM does not replace a BG meter. Always use the values from your BG meter for treatment decisions. BG values may differ from SG values. Using the SG readings for treatment decisions could lead to high or low BG.

## Section 3: Trends

When using CGM, you will want to focus on SG trends. These trends give insight into the direction and the speed that your glucose is changing. The sensor graph and trend arrows are used to show your SG trend information.



**NOTE:** When using CGM, focus less on each individual glucose number and more on the direction and speed that your glucose is changing.

### Example of sensor information on the Home screen

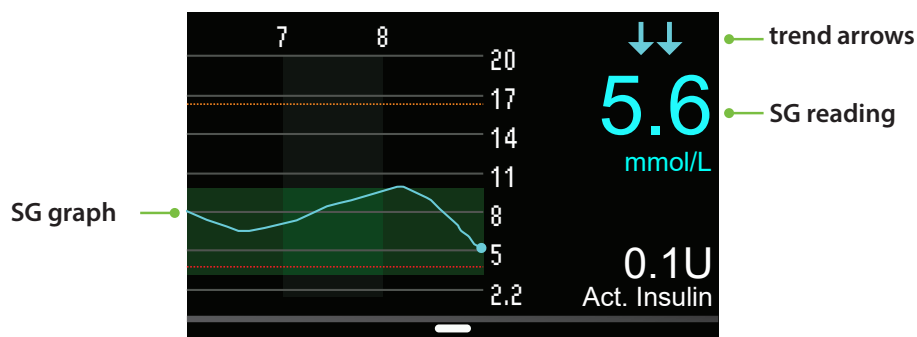

By looking at the sensor information above, you can see that the current glucose reading is 5.6 mmol/L. When you look at the graph, you can see that your SG is falling.

In this example, you see arrows above the number. The arrows indicate the rate that the glucose values are moving up or down:

- ↑ or ↓ - SG has been rising or falling by at least 0.06 but less than 0.11 mmol/L per minute.
- ↑↑ or ↓↓ - SG has been rising or falling by at least 0.11 but less than 0.17 mmol/L per minute.
- ↑↑↑ or ↓↓↓ - SG has been rising or falling by at least 0.17 or more mmol/L per minute.



**NOTE:** You may be likely to notice your glucose trending up or down after eating, giving a bolus, or when exercising.

## Section 4: Personalized alerts

The alert and SmartGuard suspend features are most beneficial if they are personalized for your needs. These features will be set during your CGM training. They can then be adjusted as you learn more about the information provided by your sensor while you wear it. Your healthcare professional will work with you to determine your initial settings and help with adjustments that need to be made.

Your alert settings apply to both Manual Mode and SmartGuard Auto Mode. However, the SmartGuard suspend settings apply only to Manual Mode. When the pump switches from Manual Mode into Auto Mode, the SmartGuard suspend settings turn off. See *GETTING STARTED WITH MINIMED™ 770G SMARTGUARD™ AUTO MODE* for information on how Auto Mode works.

The graph below shows the different settings that can be personalized for both high and low SG readings.

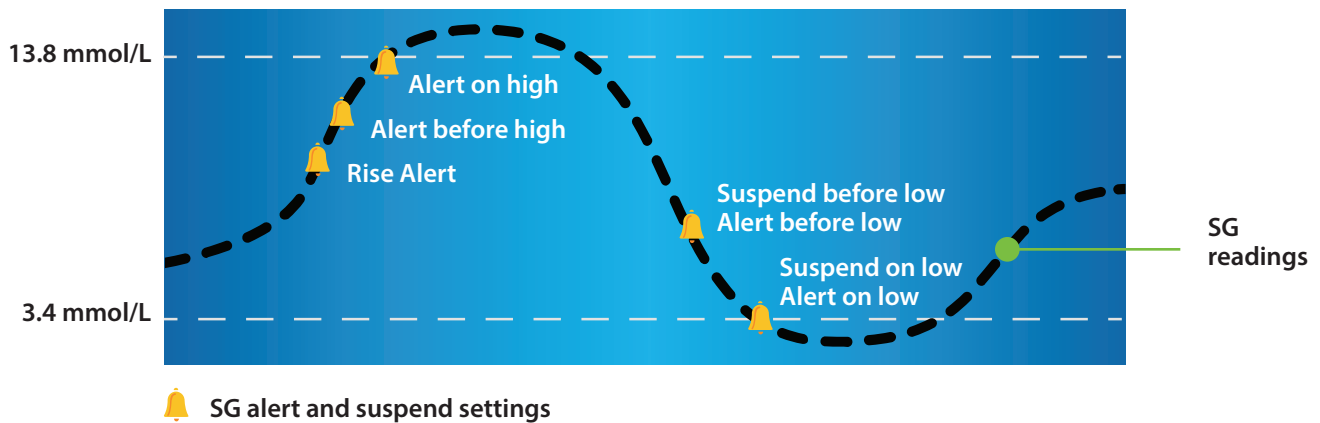

**NOTE:** Please make sure the settings prescribed for you by your healthcare professional are available at the time of your in-person training.

## Turning the Sensor feature on

Before you set up any of the SmartGuard features, you must first turn the Sensor feature on.



To turn the Sensor feature on:

- 1) Press .
- 2) Select **Options**.
- 3) Select **Utilities**.
- 4) Select **Sensor Settings**.
- 5) Select **Sensor** to turn feature **On**.

You can now access the SmartGuard features menu and enter the settings.

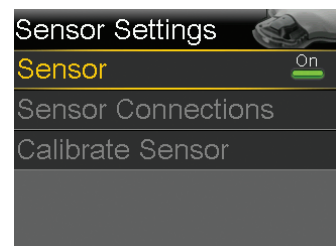
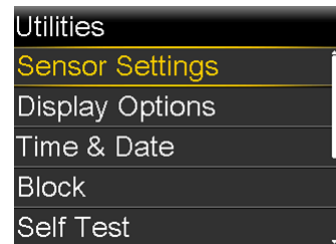

## High Setup

These settings alert you:

- **Rise Alert**—when your SG is rising rapidly
- **Alert before high**—when your SG is approaching your high limit
- **Alert on high**—when your SG has reached your high limit



 High SG alert settings

## High Limit

The first step is to set the high (**Hi**) limit. The high limit can be set from 5.6 to 22.2 mmol/L. This is the value on which other high SG settings are based. You can set up to eight high limits for different time segments throughout the day or night. The high (**Hi**) limit or limits that you enter also apply to SmartGuard Auto Mode.



**NOTE:** Your high limit is not the same as your glucose target. Your healthcare professional will help you determine the best setting, so that you are alerted only when needed.

## Alert before high

When **Alert before high** is on, you will receive an alert any time the SG is predicted to reach your high limit, making you aware of a potential high glucose level before it occurs. This can help you to evaluate what has occurred and take any necessary action as directed by your healthcare professional.

## Time before high

**Time before high** determines how many minutes before reaching the high limit that you will receive an **Alert before high**. This can be set from 5 to 30 minutes.

## Alert on high

When the **Alert on high** is on, you will receive an alert any time your SG reading reaches or exceeds your high limit. This allows you to evaluate and treat if necessary as instructed by your healthcare professional.

### ALERT ON HIGH...



Sara has been working hard to keep her glucose levels under control. Her healthcare professional has set her high limit at 12.6 mmol/L and instructed her to use the **Alert on high**. If her glucose reaches this limit, she checks her BG and takes insulin if necessary to help make sure her glucose levels return to her normal range.

## Rise Alert









The **Rise Alert** will notify you when your glucose is rising rapidly. This alert can help you understand how much your glucose levels are affected by meals or, for example, when forgetting to give a bolus.

The **Rise Alert** can be set to alert if glucose is rising as follows:

- ↑ - SG is rising at a rate of 0.06 mmol/L per minute or more.
- ↑↑ - SG is rising at a rate of 0.11 mmol/L per minute or more.
- ↑↑↑ - SG is rising at a rate of 0.17 mmol/L per minute or more.
- Custom** - SG is rising at the rate that you set. This can be set from 0.050 to 0.275 mmol/L per minute.



## Setting up your High Setup

- 1) Press .
- 2) Select **Options**.
- 3) Select **SmartGuard**.
- 4) Select **High Setup**.
- 5) Press  on the time segment.  
 If you are setting only one time segment, press . If you are setting multiple time segments, press  to the end of the first segment, and press .  
*In this example, only one time segment is set.*
- 6) Press  or  to set **Hi** limit and press .  
*In this example, the limit is set to 13.8 mmol/L.*
- 7) Press  to continue onto the next screen.

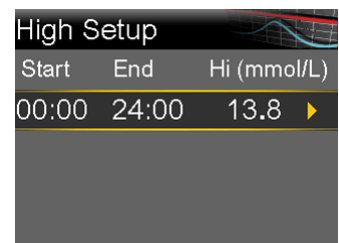
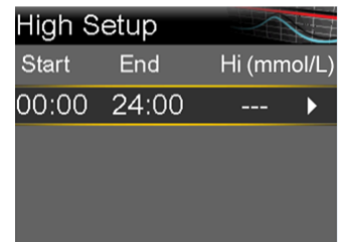
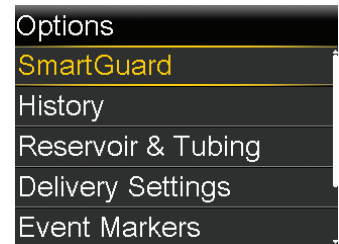
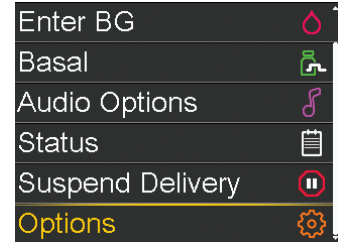

- 8) Select each feature you wish to turn on. If a feature is on, select it again to turn it back off.

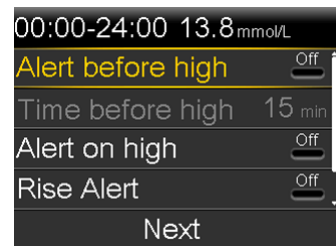

- 9) Once settings are selected, select **Next**.  
*In this example, the Alert on high has been turned on.*

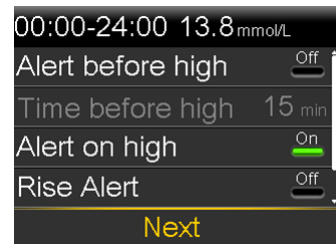

- 10) Select **Done**.

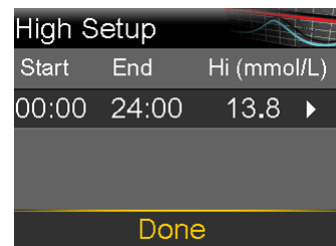

- 11) Verify that settings are correct and select **Save**.

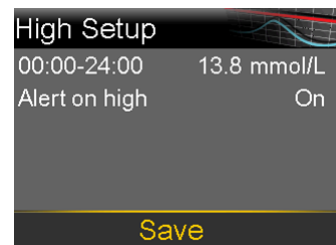

**Your High Setup is now complete.**



**WARNING:** Do not make treatment decisions, such as determining your insulin dose for meals, using the MiniMed 770G system CGM values, as they are not intended to be used to make such treatment decisions. The MiniMed 770G system CGM does not replace a BG meter. Always use the values from your BG meter for treatment decisions. BG values may differ from SG values. Using the SG readings for treatment decisions could lead to high or low BG.



**NOTE:** You can set up to 8 different time segments throughout the day and night. Each time segment can have different high SG limits and high SG alerts that work best for you during that time of day or night.

## Low Setup

Let's now look at the **Low Setup**. You can choose to be alerted before or when you have reached your low limit. You can also use the SmartGuard suspend features to have your insulin delivery automatically suspended if your SG values are approaching or have reached your low limit. The low SG settings that can be chosen are shown here:

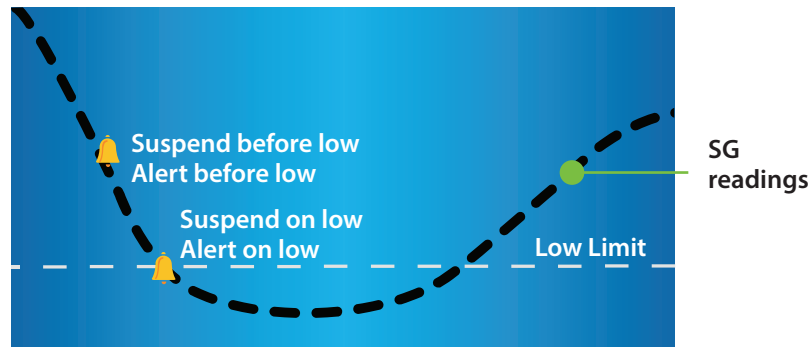

 Low SG alert and suspend settings

## Low Limit

The first step is to set the low (**Lo**) limit. This can be set from 2.8 to 5.0 mmol/L. This is the value on which the other low settings are based. You can think of this limit as the lowest SG value that you would like to avoid reaching. Furthermore, if you do reach it, you would like to spend as little time at or below it as possible. You can set up to eight low limits for different periods of the day or night.

## SmartGuard Suspend before low

**Suspend before low** is a SmartGuard suspend feature. When **Suspend before low** is on, your pump will temporarily stop delivering insulin if the SG value is approaching your low limit. This will keep you from getting additional insulin that would continue to lower your SG level.



**NOTE:** Insulin delivery will not be suspended if you are more than 3.9 mmol/L above your low limit.

## Alert before low

When **Alert before low** is set to on, you will receive an alert when you are approaching your low limit, making you aware of potential low glucose levels before they occur. **Alert before low** behaves differently depending on your SmartGuard suspend settings:

- If **Suspend before low** is on, an **Alert before low** occurs when insulin is suspended.
- If **Suspend before low** is off, an **Alert before low** occurs when the sensor predicts you will reach your low limit in 30 minutes.

## SUSPEND BEFORE LOW...



Sam uses the **Suspend before low** feature during the night. He knows that if his SG values are approaching his low limit, his insulin delivery will stop. He has the **Alert before low** set to off – he does not want to be alerted when this occurs. He is comfortable knowing the pump will stop insulin delivery and he will receive an **Alert on low** if he reaches his low limit.

## Suspend on low

**Suspend on low** is a SmartGuard suspend feature. When **Suspend on low** is set to on, your pump temporarily stops insulin delivery if your SG has reached or fallen below your low limit. This keeps additional insulin from being delivered.



**NOTE:** Only one suspend feature can be used during each time segment; you cannot turn both **Suspend before low** and **Suspend on low** on.

## Alert on Low

When **Alert on low** is on, you receive an alert any time your SG reading reaches or falls below your low limit. This allows you to check your BG and treat if necessary as instructed by your healthcare professional.



**NOTE:** **Alert on low** is automatically turned on if either **Suspend on low** or **Suspend before low** is turned on so you know that your glucose is at or below your low limit.

## Low SG X.X mmol/L (2.8 mmol/L or below):

Your system also has a fixed **Low SG X.X mmol/L** (2.8 mmol/L or below) alarm. This fixed alarm is factory set and cannot be changed or turned off. You receive this alarm if your SG reaches or falls below 2.8 mmol/L. This alarm occurs in both Manual Mode and SmartGuard Auto Mode.



**WARNING:** Do not use the Suspend on low feature to prevent or treat low glucose. Always confirm your sensor glucose reading using your BG meter, and follow the instructions of your healthcare professional to treat low glucose. Using Suspend on low alone to prevent or treat low glucose may result in prolonged hypoglycemia.

## SMARTGUARD SUSPEND ON LOW...



Alexa's healthcare professional advised her to use the **Alert before low** and the **Suspend on low** feature during the daytime. If she receives an alert before she reaches her low limit, she checks her BG and treats with carbohydrates if necessary. In case her SG still reaches her low limit, she knows she will be alerted and her pump will suspend insulin.

## Resume basal alert

In addition to suspending insulin delivery, the pump can also automatically resume delivery of basal insulin. If insulin has been suspended by either the **Suspend before low** or the **Suspend on low** feature, basal insulin delivery automatically resumes if either of these conditions apply:

- if SG values are above the low limit and are rising
- after a maximum suspend time of 2 hours

When the **Resume basal alert** is on, the alert occurs when basal insulin is automatically resumed because SG values are above the low limit and rising. If the **Resume basal alert** is off, basal insulin is still resumed, you just will not receive an alert.

If basal insulin resumes after the maximum 2 hour suspend time, you receive an alert even if the **Resume basal alert** is off. It is important that you check your BG and ensure your glucose is at a safe level.



**IMPORTANT:** The maximum time insulin will be suspended is 2 hours. Additional information regarding SmartGuard suspend features can be found in *Sensor alerts and suspend*, on page 41.



## Setting up your Low Setup

- 1) Press .
- 2) Select **Options**.
- 3) Select **SmartGuard**.

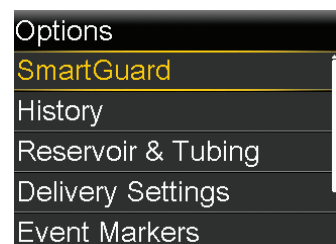
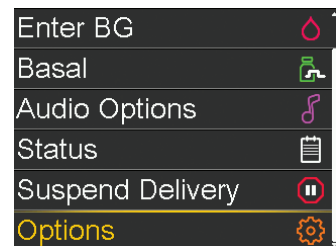

- 4) Select **Low Setup**.



- 5) Press on the time segment.

If you are setting only one time segment, press . If you are setting multiple time segments, press to the end of the first segment, and press .

*In this example, multiple time segments are set.*

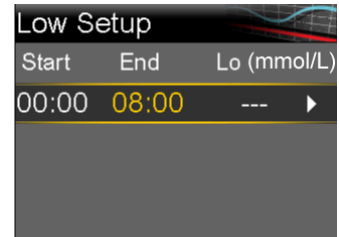

- 6) Press or to set **Lo** limit and press .

*In this example, the limit is set to 3.8 mmol/L.*

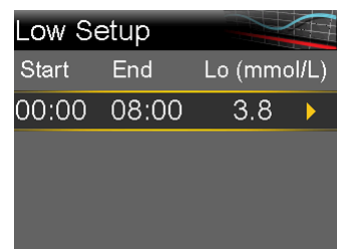

- 7) Press to continue onto the next screen.

- 8) Select each feature you wish to turn on. If a feature is on, select it again to turn it back off.

*In this example, **Suspend before low** has been turned on.*



- 9) Once settings are selected, select **Next**.



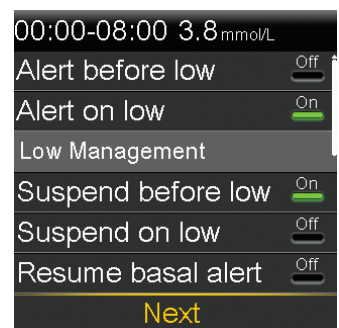

**NOTE:** Only one Suspend feature can be used during each time segment. If either Suspend feature is turned on, **Alert on low** will automatically be turned on.

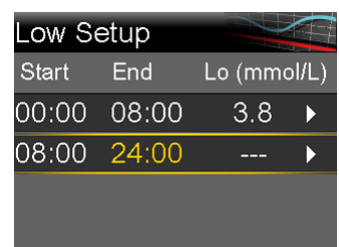

- 10) Press on the time segment.

- 11) Press to set the **End** time of the second segment and press .



12) Press  or  to set the **Lo** limit and press .

13) Press  to continue onto the next screen.

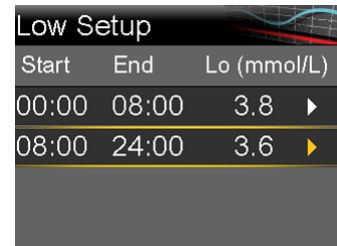

14) Select each feature you wish to turn on. If a feature is on, you can select it again to turn it back off.

*In this example, **Alert before low**, **Suspend on low**, and **Resume basal alert** have been turned on.*

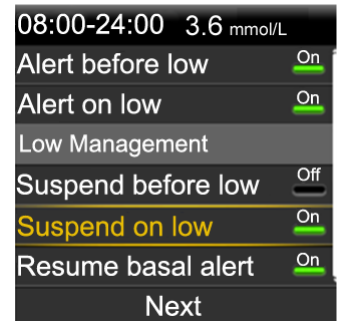

15) Select **Next**.

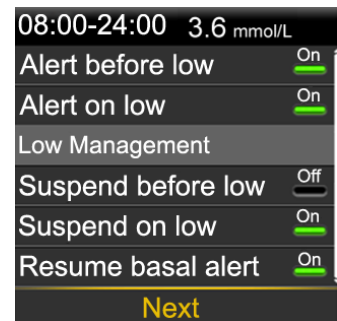

16) Select **Done**.

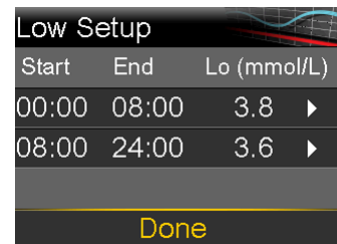

17) Verify that settings are correct and select **Save**.

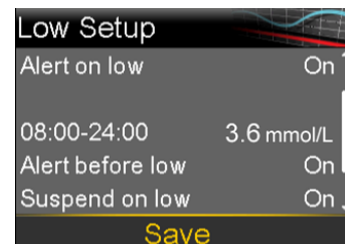







**Your Low Setup is now complete.**



**NOTE:** You can set up to 8 different time segments throughout the day and night. Each time segment can have different low limits and low SG alerts that work best for you during that time of day or night.

## Snooze

The **High Snooze** and **Low Snooze** features can be set for the amount of time that you want to wait to be reminded that an alert condition still exists. Once a high or low alert is received and cleared, you will be alerted again only if the alert condition still exists after the snooze time you have set. The snooze time for your high SG alerts can be set from 5 minutes to 3 hours. The snooze time for your low SG alerts can be set from 5 minutes to 1 hour.

- 1) Press .
- 2) Select **Options**.
- 3) Select **SmartGuard**.
- 4) Select **Snooze**.
- 5) Select **High Snooze**.
- 6) Press  or  to set the desired time and press .
- 7) Select **Low Snooze**.
- 8) Press  or  to set the desired time and press .
- 9) Verify that the settings are correct and select **Save**.

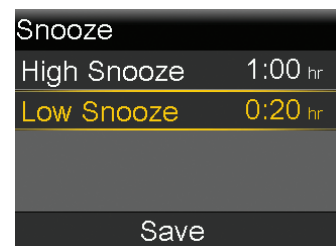
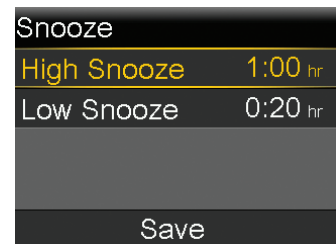

**NOTE:** Additional details about the SmartGuard suspend features can be found in the *Training handouts, on page 49*. See the *MiniMed™ 770G SYSTEM USER GUIDE* for a complete explanation of the technical and operational aspects of your pump.







**NOTE:** The SmartGuard **Suspend on low** and SmartGuard **Suspend before low** features are automatically turned off when SmartGuard Auto Mode becomes active.

**SNOOZE...**

Robert's healthcare professional instructed him to turn **Alert on high** on and to set his **High Snooze** at 2 hours. If his SG reaches his high limit, he checks his BG and gives a bolus if he needs it. His pump will alert him again in 2 hours if his glucose level is still at or above his high limit.

## Changing High or Low Setup

As you use CGM, you and your healthcare professional may find that changes need to be made to the existing settings. To make these changes:



- 1) Press .
- 2) Select **Options**.
- 3) Select **SmartGuard**.
- 4) Select **High Setup** or **Low Setup**.
- 5) Select **Edit**.
- 6) Select time segment you wish to change.
  - a. Change **End** time if necessary and press .
  - b. Change **Hi** or **Lo** limit if necessary and press .
  - c. Press  when the arrow is highlighted to continue onto the next screen.
- 7) Select any feature that is off if you wish to turn it on. Select any feature that is on if you wish to turn it off.
- 8) Select **Next**.
- 9) When finished, select **Done**.
- 10) Verify settings are correct and select **Save**.

## Alert Silence feature

The **Alert Silence** feature allows you to silence sensor alerts for a set period of time. If a sensor alert occurs when the **Alert Silence** feature is on, a message is displayed to notify you that a sensor alert occurred and the notification light flashes, but there is no beep or vibration. You can go to Alarm History in the History menu to see which sensor alert or alerts occurred. If you have not cleared the message when the **Alert Silence** period ends, the pump will beep, vibrate, or beep and vibrate until cleared.



### To set Alert Silence

- 1) Press .
- 2) Select **Audio Options**.
- 3) Select **Alert Silence Options**.
- 4) Select the alerts that you want to be silenced.
- 5) Select **Duration**.
- 6) Press  to set the time that you want alerts to be silenced and press .
- 7) Select **Begin**.

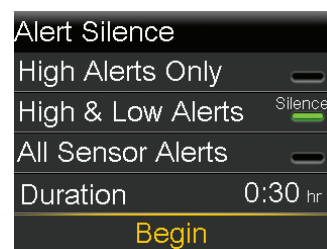
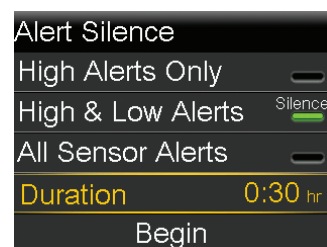

Alerts will automatically return to audio or vibrate at the end of the duration that you set. The **Low SG X.X mmol/L** (2.8 mmol/L or below) alarm and **Alert on low** alert cannot be silenced.

### SILENCING ALERTS...



Sandra uses the **Alert Silence** feature when she is in class so that she does not disrupt her classmates if an alert occurs. She routinely looks at her pump to check for alerts, and can take action if necessary.

## Section 5: Pairing your pump and transmitter

Before using the sensor for the first time, you will need to pair the pump with the transmitter so that they can communicate with each other. This allows the sensor information to be displayed on the pump screen.



### To pair your pump with the transmitter:

- 1) Attach your transmitter to the charger and make sure it is fully charged.

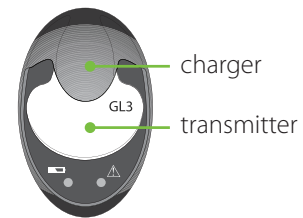

**NOTE:** No lights are flashing on the charger when the transmitter is fully charged. For more information on charging the transmitter, see *Charging and storing the Guardian Link (3) transmitter*, on page 45.

- 2) Press .
- 3) Select **Options**.
- 4) Select **Utilities**.
- 5) Select **Device Options**.

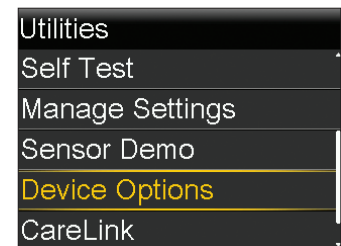

Only one transmitter can be paired with the pump at one time. When you need to pair a new transmitter, you must first select **Manage Devices**, select the old transmitter number, and then select **Delete**.

- 6) Select **Pair Device**.  
The New Device screen appears.

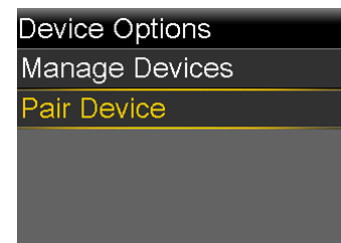

- 7) Place the transmitter, still attached to the charger, next to the pump.



# Getting started | Pairing your pump and transmitter

- 8) Select **Search** on your pump and immediately remove the transmitter from the charger.

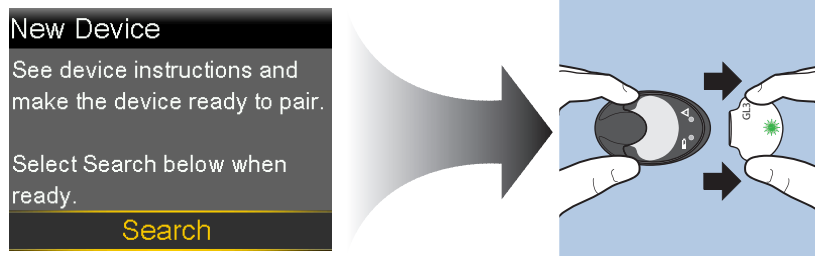

The following happens when you start the search process:

- On your pump, a message appears to let you know your pump is searching for compatible devices.
- On your transmitter, a green light starts to flash.



**NOTE:** The search process can take up to two minutes. You cannot access your pump screens or suspend your pump during the search process.

The Select Device screen appears with a list of available devices.

- 9) Select the CGM device that matches the serial number on the back of the transmitter.



- 10) Ensure the transmitter serial number on your pump screen matches the serial number on the back of your transmitter, and then select **Confirm**.

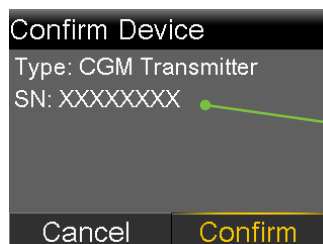

Your pump displays a message if the pump and transmitter are paired successfully. If the Sensor feature is turned on, the Connection icon  appears on the Home screen.

If your pump does not find your transmitter, the Device not found alert appears. See the *MiniMed™ 770G SYSTEM USER GUIDE* if your pump does not find your transmitter.



**NOTE:** These steps only need to be done as a first time set-up of the transmitter. You will not have to repeat them every time you start a new sensor.

## Section 6: Inserting and starting the sensor

Before you insert your sensor, gather all of your supplies:

### Guardian Sensor (3) system components\*

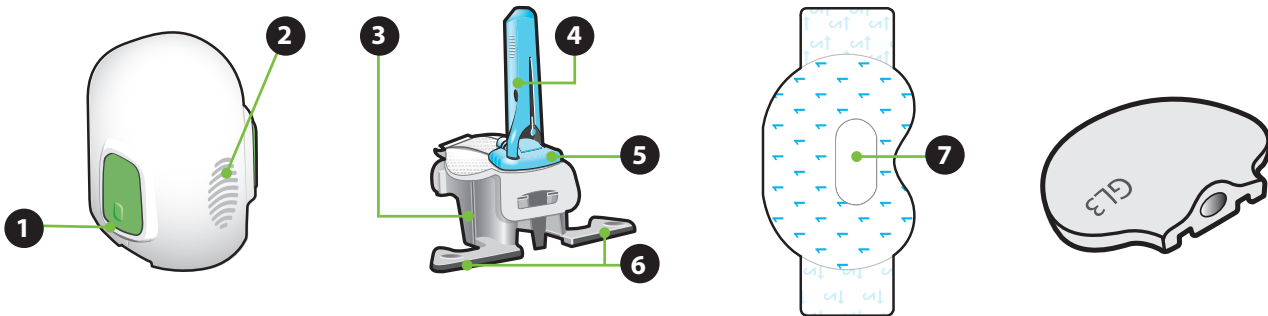

#### One-press sarter

- 1 Bump on button
- 2 Thumb print

#### Guardian Sensor (3) & plastic pedestal

- 3 Pedestal
- 4 Needle housing
- 5 Sensor
- 6 Pedestal feet

#### Oval tape

- 7 Precut hole

#### Guardian Link (3) transmitter

- **One-press sarter** is required in order to insert the sensor properly.
- **Guardian Sensor (3)** is individually packaged and comes attached to a plastic pedestal which is necessary for proper loading into the sarter.
- **Oval tape** is required to keep the sensor securely in place.
- The **Guardian Link (3) transmitter** is connected after the sensor is inserted and covered with the oval tape.

\*For more details on the Guardian Sensor (3) components, consult the user guides for Guardian Link (3) transmitter, Guardian Sensor (3), and one-press sarter.

## Selecting your site

Your sensor can be inserted in any of the shaded areas according to your age.



**NOTE:** Assistance will likely be needed for sensor insertion into the back of the upper arm and into the buttocks. Some users found it difficult to insert the sensor into their arm/buttocks by themselves.

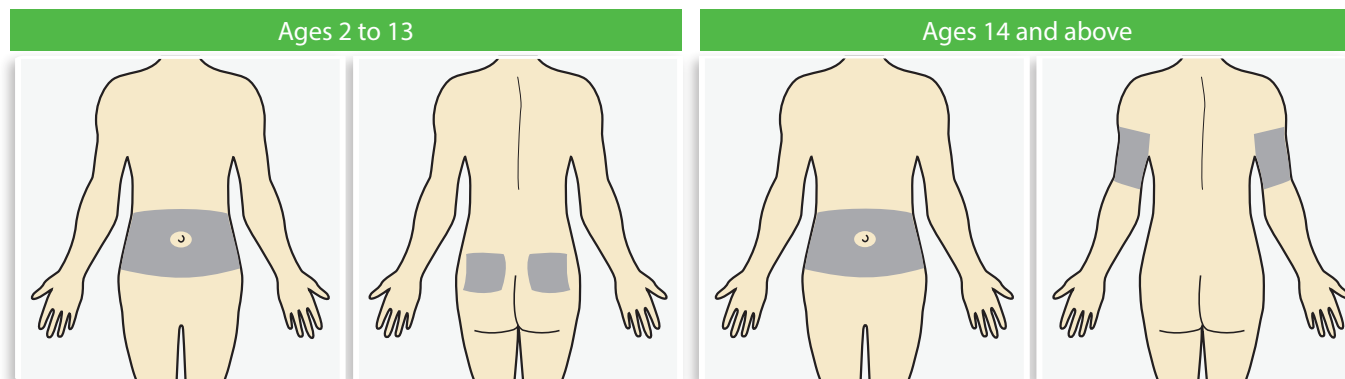

The Guardian Sensor (3) has been studied and is approved for use in the following sensor insertion sites by person of the following ages:

Approved Age	Sensor Insertion Site
2-13	Abdomen and Buttock
14 and above	Abdomen and Arm

The sensor insertion site should be at least:

- 2 inches (5 centimeters) from your navel.
- 1 inch (2.5 centimeters) from your insulin pump infusion site.
- 1 inch (2.5 centimeters) from any manual insulin injection site.

## For best sensor glucose performance, avoid sites:

- where clothing may rub or constrict (for example, your belt line).
- where your body naturally bends a great deal which may cause the sensor to pull out.
- where there are scars, hardened tissue, or stretch marks.
- where there is a great deal of motion or friction.

## Preparing your site

- Wash your hands with soap and water.
- Clean the selected site with an alcohol swab and allow the alcohol to dry. Do not use alcohol pad containing adhesive prior to sensor insertion.

## Inserting your sensor

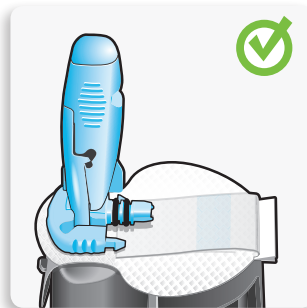
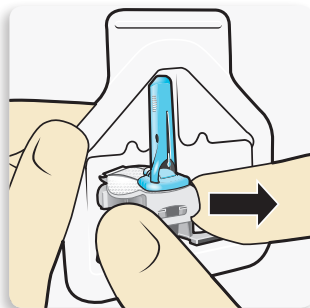
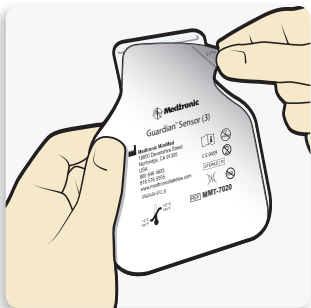

Correct

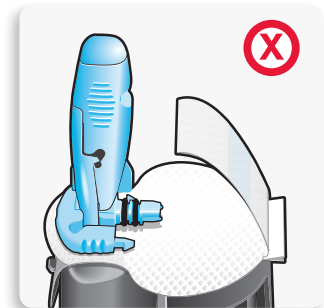

Incorrect

**1** **Open the sensor package.** Pull the corner of the paper covering to open the sensor package.

**2a** **Hold the sensor by the plastic pedestal.** Remove the sensor with attached pedestal by holding the pedestal only. Place the sensor and pedestal on a clean, flat surface (such as a table).

**2b** **Tuck the adhesive tab.** Make sure that the sensor's adhesive tab is tucked under the sensor connector and snaps.



**NOTE:** Refer to the illustrations for correct and incorrect ways to hold serter for loading.

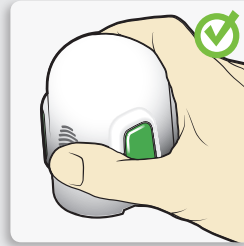

**Correct**



**Incorrect**

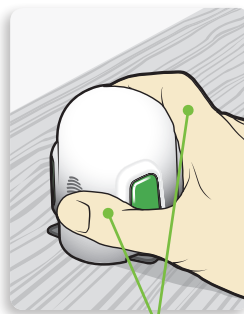
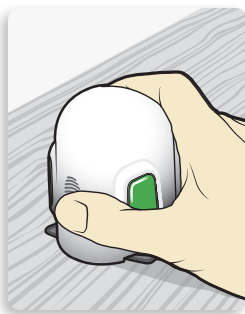
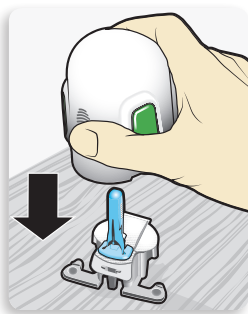

Fingers are **NOT** holding the side buttons.

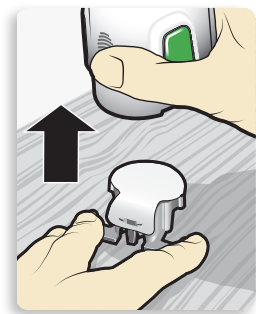
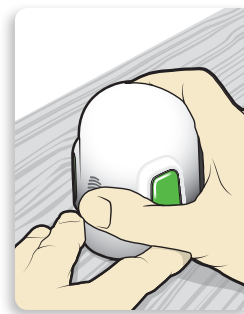

**3 Load the sensor into the serter.** Grip the serter exactly as shown **with your thumb placed on the thumb print on the serter. Do not hold the side buttons.** Push the serter down onto the pedestal until the base of the serter sits flat on the table.

**4 Detach the serter from the pedestal.** To detach the serter from the pedestal, grip the serter as shown with thumb placed on thumb print on the serter. With the other hand, place two fingers on the pedestal arms, and slowly pull the serter straight up.



**NOTE:** Make sure that the pedestal is firmly on the table before pulling the serter away.



**CAUTION:** Do not detach the pedestal from the serter in mid-air as this may damage the sensor.



**NOTE:** The thumb print on the serter can be used for either left-handed or right-handed insertion.



**NOTE:** The sensor remains inside the serter after removing the pedestal. The arrows on both sides of serter indicate location of the sensor needle.

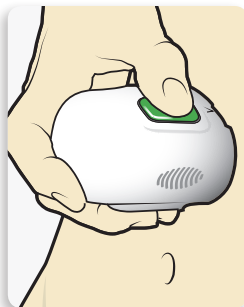
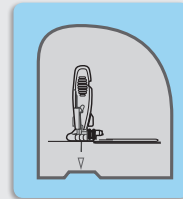

**5a Place the serter on your body.** Hold the serter steadily against your cleaned insertion site, without pushing the serter too deeply into the skin.

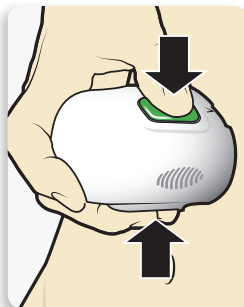

**5b Insert the sensor.** Press and release the **bump** on both buttons at the same time. Do not pull the serter away from your body just yet.

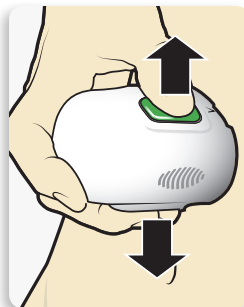

**5c Hold the serter against your body.** Continue to hold the serter against your body for at least five seconds to allow the adhesive to stick to your skin.

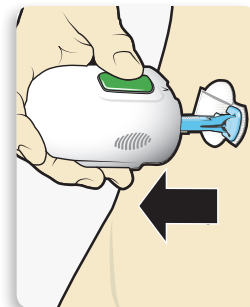

**5d Remove the serter from your body.** Slowly pull the serter away from the skin, making sure the buttons are not pressed.



**NOTE:** Failing to hold the serter securely flat against the body may allow the serter to spring back after pressing the buttons and result in improper insertion of the sensor.

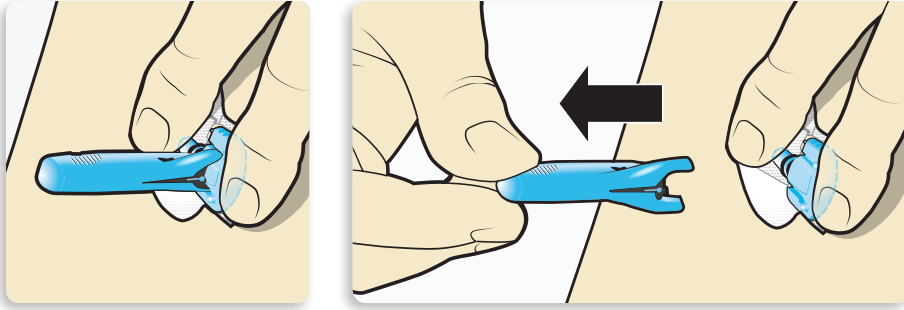

- 6 Remove the needle housing.** Gently hold the base of the sensor against the skin with one hand. With the other hand, hold the needle housing at the top and slowly pull it straight away from the sensor. Dispose of the needle housing in a sharps container.



**NOTE: Apply additional liquid adhesive.** You may use an optional adhesive under the adhesive pad prior to removing the liner. Allow it to dry.

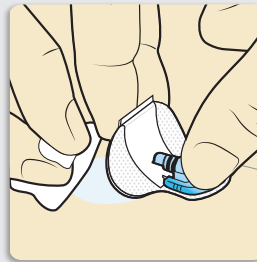

**IMPORTANT:** All sensor tapes and adhesives stick best when you apply pressure after putting them on your skin. Doing so helps the sensor stay securely placed and fully inserted.

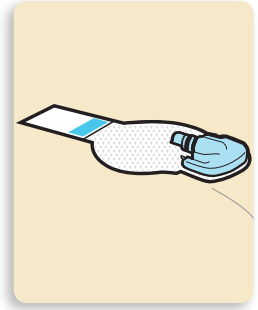
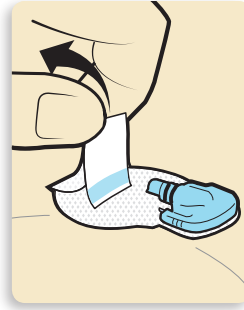
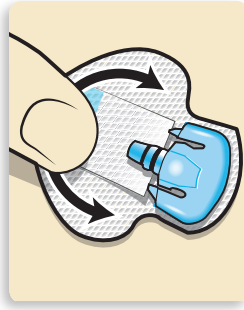
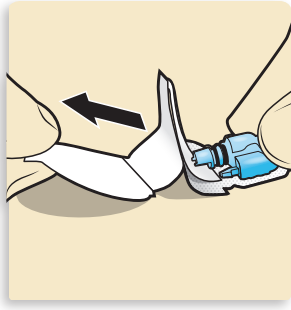
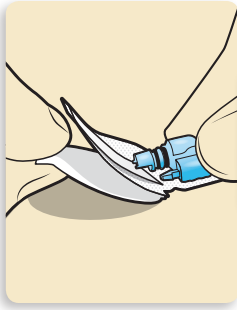

## 7a Remove the adhesive pad liner.

Hold the sensor in place and gently remove the adhesive liner from under the adhesive pad. Do not remove the liner on the rectangular adhesive tab yet.

## 7b Press the entire adhesive pad to your skin.

Firmly press the adhesive against the skin and smooth the entire adhesive pad so that it sticks to your skin.

## 8a Untuck the adhesive tab.

Untuck the adhesive tab from under the sensor connector.

## 8b Straighten the adhesive tab.

Straighten the adhesive tab so that it lies flat against your skin, but do not remove the adhesive liner yet.



**NOTE:** The Guardian Sensor (3) adhesive is sensitive to pressure. Continue applying pressure on the adhesive to ensure that the sensor remains inserted in the skin for up to 7 days of wear.

## Taping your sensor

Before you connect the transmitter to your sensor, it is very important that you properly secure the sensor against your skin using the provided tape.

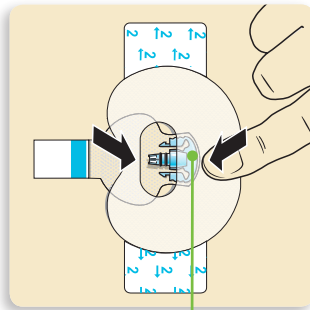
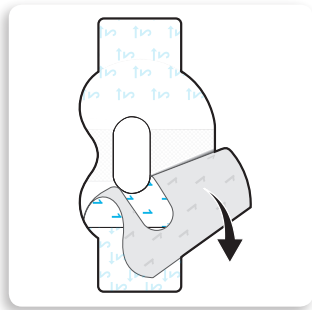

Wide part of tape covers half of sensor base.

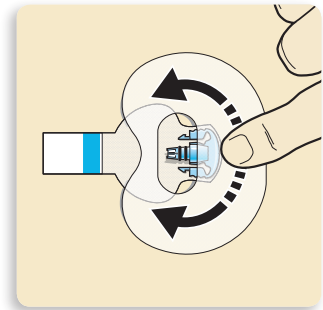
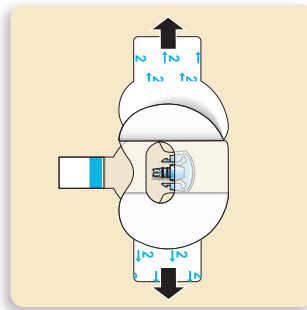

**1** Remove liner 1.

**2** Apply the tape as shown and press it down firmly.

**3** Remove liner 2 from each side.

**4** Smooth the tape.



**IMPORTANT:** All Guardian Sensor (3) tapes and adhesives stick best when you continue to apply pressure after putting them on your skin. Doing so helps the sensor stay securely placed and fully inserted.

## Connecting your transmitter

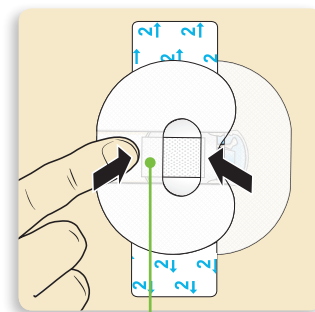
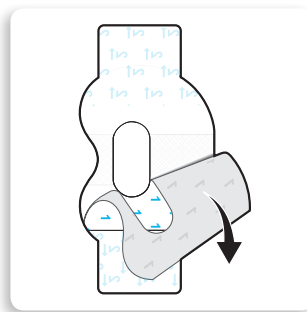
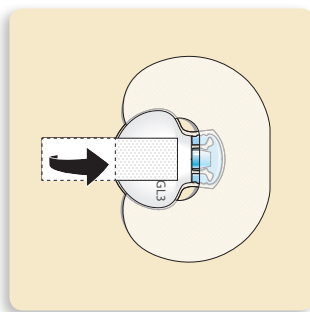
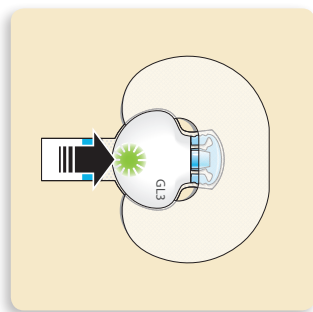

Wide part of tape covers end of transmitter and skin.

**1** Connect the transmitter to the sensor. A green light flashes 6 times when the sensor is properly connected to the transmitter.

**2** Remove the liner from the adhesive tab. Cover the transmitter with the adhesive tab. Do not pull the tab too tightly.

**3** To apply the 2nd tape, remove liner 1.

**4** Rotate the 2nd tape and place the tape over the transmitter. Press it down firmly.



**NOTE:** Wait for the green light on the transmitter to flash. If the green light does not flash, refer to the Troubleshooting section of your transmitter user guide.



**IMPORTANT:** If you do not see a green light flashing on the transmitter after it is connected to the sensor, disconnect the transmitter and place it back on the charger to ensure that it is fully charged. Then reconnect the transmitter to the sensor.

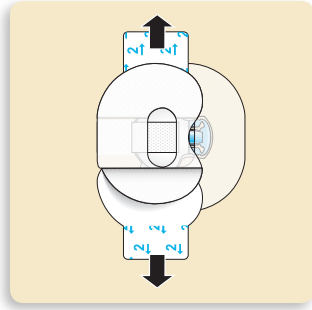

**5** Remove liner 2 from each side.

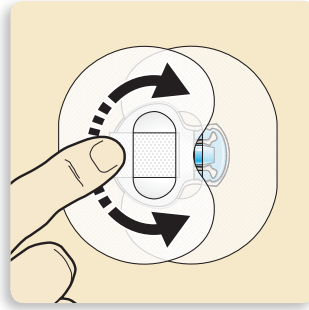

**6** Smooth the tape.



**NOTE:** Check your sensor site regularly. Apply additional tape if the sensor and transmitter are not secure.

It is very helpful to remember the order of these four steps when changing your sensor:

1. **Insert** the sensor.
2. **Tape** the sensor in place.
3. **Connect** the transmitter.
4. **Apply** a second oval tape.



**NOTE:** When your transmitter is connected to your sensor they form a water-tight seal to a depth of 2.4 meters (8 feet) for up to 30 minutes. You can shower and swim without removing them.



**NOTE:** Properly applying the oval tape is key to ensuring your success with the sensor. Due to the sensor's small size and flexible nature, the oval tape helps to secure it from body motion or physical activity that can cause it to be pulled out.

## Checking for proper tape application

It is important to check your sensor site periodically to make sure the sensor is still secure and has not been pulled out. If the sensor has been pulled out, do not try to push it back into place. A new sensor may need to be inserted.

### Correct

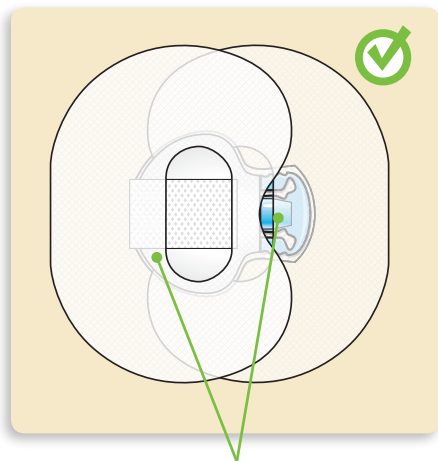

Oval Tape is covering the sensor, the skin around sensor, and the back of the transmitter.

## Starting the sensor

Once you have inserted the sensor and connected the transmitter, the pump and transmitter begin to communicate.

Make sure your pump is on the Home screen so that the **Sensor connected** message will be displayed when the sensor is ready to be started. *This typically takes less than a minute, but may take up to 10 minutes.*

- 1) Select **Start New Sensor**.

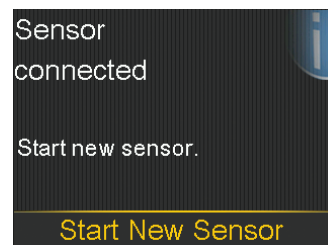

- 2) The **Sensor warm-up started** message appears.

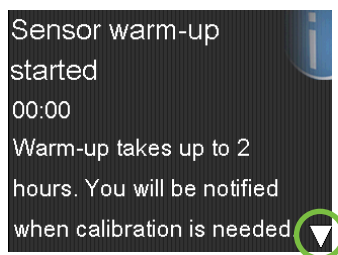

- 3) Press  and then  to clear.

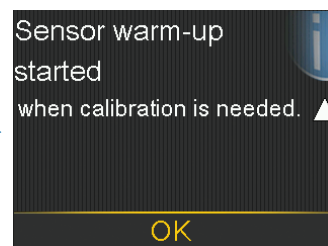

- 4) **Warm up...** appears on the Home screen until the sensor is ready for the first calibration.

*If 15 minutes have passed and the Warm up bar does not appear or it looks like it is not progressing, look into the **Quick Status** screen. If you see the time of **Next cal** listed, the sensor is in Warm up.*

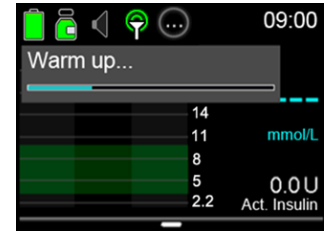

**NOTE:** The next time you connect a transmitter, you will see these screens. Select **Start New Sensor** if you have just inserted a new sensor. Select **Reconnect Sensor** if you have only disconnected and reconnected the transmitter.

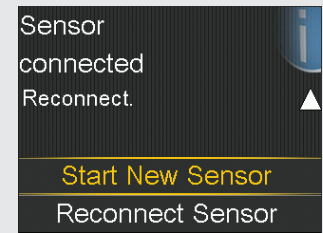
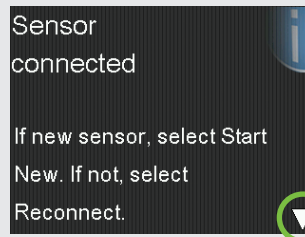

**NOTE:** The *Quick Reference Guide for Using the One-press Sertter with Guardian™ Sensor (3)*, on page 53 is available in the *Training handouts on page 49* to help you during your sensor setup and sensor insertion.

## Section 7: Calibration

Your CGM system requires BG meter readings in order to provide you with SG readings. These BG meter readings are entered into the pump and are for sensor calibrations. Calibration is essential for optimal CGM performance. CGM does not eliminate the need for BG meter checks.

To calibrate, you must use a *fingerstick* blood sample to check your BG on your meter, and then enter that value into your pump. The pump accepts BG meter readings between 0.6 and 33.3 mmol/L. The BG meter reading must be between 2.2 and 22.2 mmol/L to calibrate.



**WARNING:** Always use the fingertip for blood samples used for calibrating the sensor while in SmartGuard Auto Mode. The fingertip was the only site studied for use with Auto Mode. Do not use blood samples from the palm to calibrate the sensor as this site was not studied for use with Auto Mode and the performance of the system is not known.

After inserting a new sensor, a calibration is needed:

- Within 2 hours after you connect the transmitter to your sensor and start the warm-up period



**NOTE:** Your pump notifies you with a **Calibrate now** alert when it is ready for its first calibration.

- Again within 6 hours (first day of inserting sensor only)
- Again every 12 hours
- When the system detects that a calibration is needed for optimal performance

After the first day, the minimum number of calibrations required is one every 12 hours, but you may receive a **Calibrate now** alert if one is needed sooner. Calibrating three or four times per day is optimal. It is best to calibrate when your glucose is not changing rapidly. For example, before meals is often a good time to calibrate. Calibrating when there are **↑↑, ↓↓, ↑↑↑, ↓↓↓** may decrease sensor accuracy.



**IMPORTANT:** BG readings should be entered immediately. Avoid the use of an old BG reading or a BG reading used for previous calibrations. Wait at least 15 minutes in between calibration attempts.



**NOTE:** Calibrations are necessary in order to continue to receive SG readings, alerts, and alarms.

Within two hours after starting a new sensor, or any other time a calibration is necessary, you will receive a **Calibrate now** alert. If you cannot calibrate right away (for example, if you are driving or in a meeting), you can set the **Snooze** to remind you to calibrate in the time that you set. You can change the time if you desire.

If you plan to check your BG and calibrate right away, simply select **Snooze**.

Once you select Snooze, **Calibration required** will appear on the Home screen until you enter a BG to calibrate.

You will not receive SG readings or sensor alerts and alarms until a calibration BG is entered.

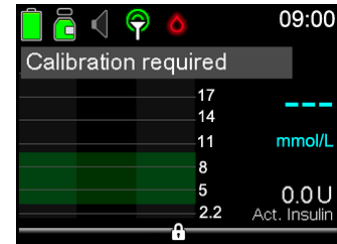
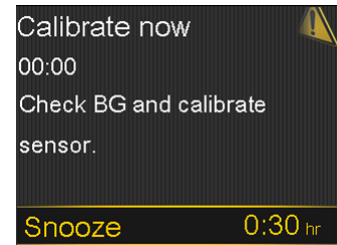

## Calibrating the sensor

There are several different ways that you can enter a BG reading to calibrate the sensor.



### Calibrate by using the Accu-Chek® Guide Link meter

When you use the Accu-Chek Guide Link meter, the meter value automatically appears on the BG Meter screen.

- 1) Check your BG. Press  on the meter to send the BG reading to the pump.
- 2) Select **Yes** to confirm the BG meter reading.

If you do not believe the meter result is accurate, do not confirm now. Select **No**, wash your hands, and recheck your BG.



- 3) Select **Calibrate Sensor** to calibrate using the BG value.

If you plan to give a bolus using the Bolus Wizard feature, select **Bolus**.

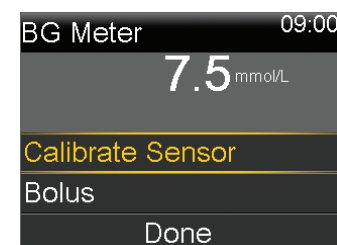
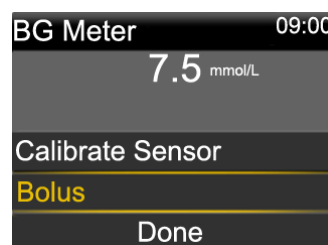

Select **Done** if you wish to do neither.



## Calibrate through Enter BG

You are able to calibrate through Enter BG.

- 1) Press
- 2) Select **Enter BG**.
- 3) Select **Enter BG**.
- 4) Press or to enter your BG reading and press .
- 5) Select **Save**.

A message appears asking if you want to calibrate using the entered BG.

- 6) Select **Yes** if you want to calibrate.  
Select **No** if you do not want to calibrate.
- 7) The Home screen appears, indicating that your pump is calibrating.





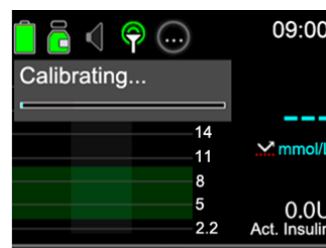
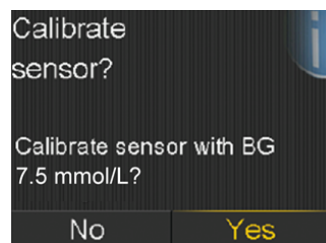
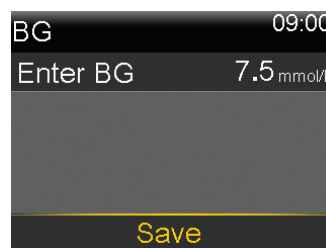
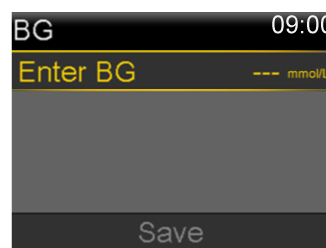
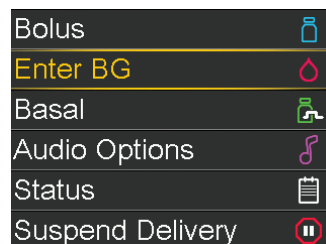





**NOTE:** You can perform other tasks while your pump is calibrating.





## Calibrating through the Bolus Wizard feature

You are able to calibrate when using the Bolus Wizard feature.

- 1) Press .
- 2) Select **Bolus**.
- 3) Select **Bolus Wizard**.
- 4) Press .
- 5) Press  or  to enter BG value and press .
- 6) Press .
- 7) Press  to enter your carbs and press .
- 8) Select **Next**.
- 9) Select **Deliver Bolus**.
- 10) Press  and select **Yes** to calibrate sensor.

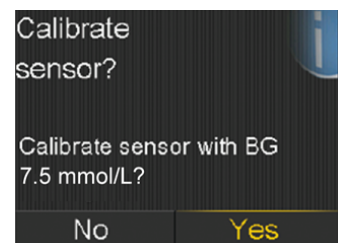
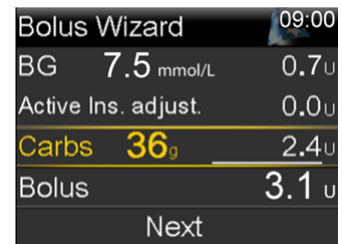

You can also calibrate through the Sensor Settings and Event Markers menu. For complete instructions, see the *MiniMed™ 770G SYSTEM USER GUIDE*.

After you have entered a BG for calibration, the Home screen shows you that the system is calibrating.

You will start seeing SG readings again within 5 minutes.

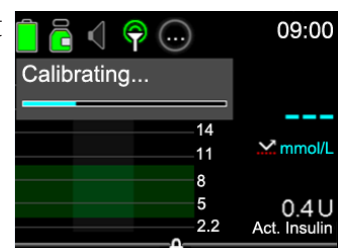

**WARNING:** If you notice a large difference between your BG meter reading and SG readings, wash your hands and do another BG fingerstick test to help ensure a more accurate reading. Check the sensor site to ensure the sensor overtape is still holding the sensor in place. If it is not, you will need to remove and insert a new sensor.

## Calibration reminder

You can use the **Calibration reminder** to give you notice before the next calibration is necessary. For example, let's say you calibrated at 07:00 and your reminder is set for 4 hours. Since your next calibration would be due at 19:00 (12 hours), you would receive a **Calibration reminder** at 15:00, which is 4 hours before the calibration is due. This can help ensure that you calibrate 3 or 4 times a day. The **Calibration reminder** default setting is On with a reminder time of 1:00 hour.



### To change the Calibration reminder

- 1) Press
- 2) Select **Options**.
- 3) Select **Reminders**.
- 4) Select **Calibration**.
- 5) Press to **Time** and press .
- 6) Press or to desired time and press .

*In this example, the reminder is set for 1 hour.*

- 7) Select **Save**.

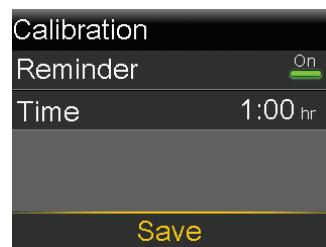

## CALIBRATE BEFORE BED...



Pam does not want to be awakened during the night by a **Calibrate now** alert, so she checks her BG and calibrates her sensor before she goes to bed.

## Section 8: Reading the sensor display

Once the sensor starts to send SG readings to the pump, the Home screen shows your readings in a way that is similar to the example shown below.

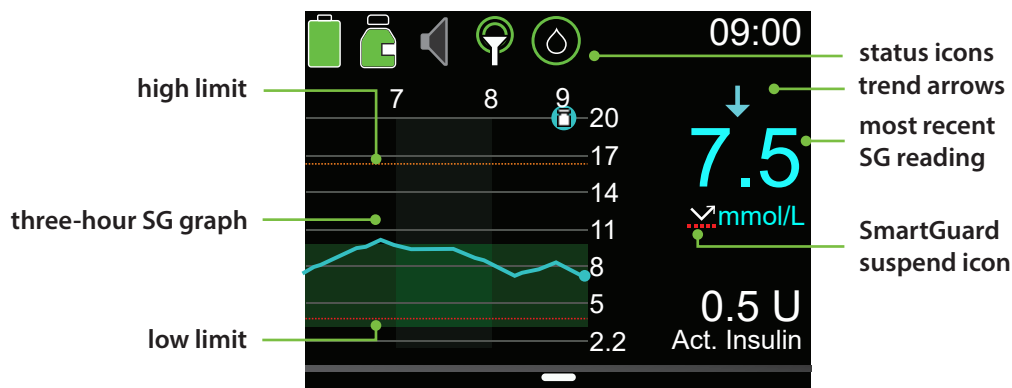

**NOTE:** This is the sensor display when your pump is in Manual Mode. The display is different when your pump is in SmartGuard Auto Mode. See *GETTING STARTED WITH MINIMED™ 770G SMARTGUARD™ AUTO MODE* for information about Auto Mode display.

### Status icons

In addition to the pump icons, you will see additional sensor icons when using CGM.



**Connection:** The connection icon appears green when the Sensor feature is on and your transmitter is successfully communicating with your pump. The connection icon appears with a red cross when the Sensor feature is turned on, but the transmitter is not connected, or communication with your pump has been lost.



**Calibration:** The calibration icon shows the approximate time left until your next sensor calibration is due. The calibration icon appears only when the Sensor feature is turned on. The color and the circle around the icon indicate the status of calibration. When your sensor is fully calibrated, the icon has a solid green circle around it. As the time for your next sensor calibration approaches, the green circle around the icon becomes smaller, and the color of the icon changes. When the icon turns red, a sensor calibration is required. If the time until your next sensor calibration is unavailable, the icon has a solid blue circle around a question mark. The circle shows three dots when a new sensor is connected or when the sensor is calibrating. This also occurs withing 15 minutes of a Calibration not accepted alert.



**Audio icon:** If Alert Silence is on: audio , vibrate , or audio and vibrate .

## SmartGuard suspend icon

During any time segment when either **SmartGuard Suspend before low** or **SmartGuard Suspend on low** is set to On, you will see the SmartGuard suspend icon on the Home screen.



**Suspend before low** or **Suspend on low** is on and ready. If either suspend feature becomes active, the icon will flash while insulin delivery is stopped.



**Suspend before low** or **Suspend on low** is on but unavailable. This can be due to a recent suspend event or when no SG values are available.

## Sensor status

You can go to the Sensor status menu to see, for example, when your next calibration is due, time left on your sensor, and battery life remaining on your transmitter.

- 1) From the Home screen, press .
- 2) Select **Status**.
- 3) Select **Sensor**.

You will also see additional sensor status information in the **Notifications**, **Quick Status**, and **Settings Review** screens.

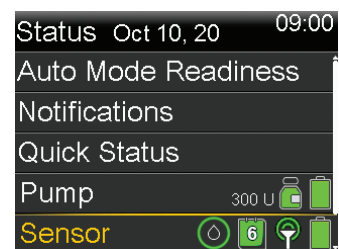

## Current sensor value

The most current sensor reading is displayed on the Home screen. This is updated every 5 minutes. The sensor reads glucose values from 2.2 to 22.2 mmol/L.



**NOTE:** One, two, or three trend arrows may sometimes appear above the SG reading. These give you insight on the speed and direction that your SG is moving. See *Trends*, on page 3 to review these arrows.

## Sensor graph

A graph that shows the last 3 hours of SG readings is displayed on the Home screen. Your high glucose limit entered in your sensor settings is shown in orange, and your low glucose limit is shown in red.

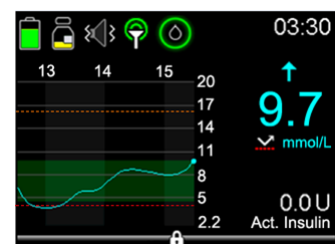

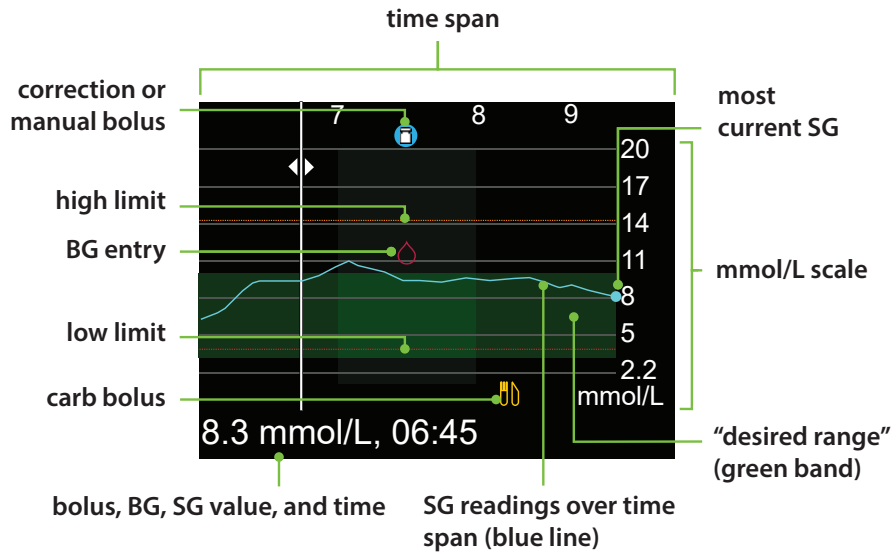

## Additional sensor graphs

In addition to the 3-hour graph, you can also view 6-hour, 12-hour, and 24-hour glucose trend graphs.



The graph shows a range of SG values from 2.2 to 22.2 mmol/L. The green band across the screen represents an SG range from 3.9 to 10.0 mmol/L. The blue line shows your actual SG values over the time span. At the right end of the blue line is a blue dot representing the most current SG value.

Details about correction bolus, BG entry, and carb or food bolus are shown on the graph. To view details for an icon, look for the icon on the graph, and press  $\leftarrow$  or  $\rightarrow$  to scroll to that icon. The details for that icon are located along the bottom of the screen. Icons shown on the graph are:





-  – indicates either a correction bolus or manual bolus
-  – indicates a BG entered either manually or using a meter
-  – indicates a bolus that includes a carb entry; it displays for a carb only or a carb plus correction bolus

Press  $\leftarrow$  or  $\rightarrow$  to cycle through the time span. The SG values and times, BG readings and times, and Bolus amounts display along the bottom of the screen.

A bolus amount followed by an (N) indicates a Normal bolus delivered through the bolus feature. A BG entry is labeled BG, for example: BG, 6.7 mmol/L, 12:30. An SG is displayed with the value and time only, for example: 6.7 mmol/L, 12:35.

Press  $\wedge$  or  $\vee$  to change the time span shown on the graph. The choices are 3 hours, 6 hours, 12 hours, and 24 hours.

To access these graphs:

- 1) From the Home screen, press .
- 2) Press  to scroll back over the graph. Sensor values will be shown at the bottom of the graph.
- 3) Press  to see the 6-hour, 12-hour, and 24-hour graphs.
- 4) Press  to return to the Home screen.



**NOTE:** Remember to download the MiniMed Mobile app onto your iOS or Android device. More information about the MiniMed Mobile app can be found in the *MINIMED™ MOBILE APP USER GUIDE* sent with your pump.



## Section 9: Sensor alerts and suspend

Alerts are an important part of using CGM. We discussed some of these alerts earlier in *Personalized alerts*, on page 4. A table of the most common alerts that occur can be found in the *Quick Reference Guide for Sensor Alerts*, on page 51.

You are notified of an alert or a SmartGuard suspend event in the following ways:

- The notification light flashes.
- The pump beeps, vibrates, or beeps and vibrates depending on your Audio Options setting.
- A message that describes the alert or suspend event appears on the pump.

Follow these steps when you receive an alert:

1. Read the text on the screen. Take any action necessary.
2. Press .
3. Press  on the desired option.

### Sensor alerts

This is an example of the **Alert before low** screen.

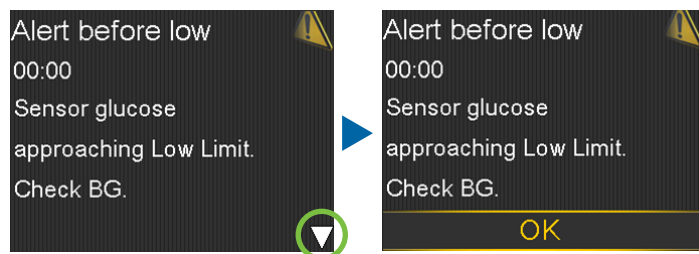

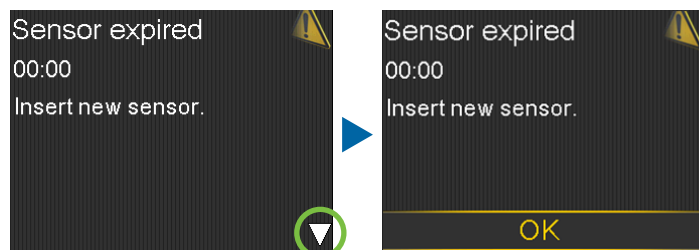

This is an example of the **Sensor expired** screen.



## SmartGuard suspend features

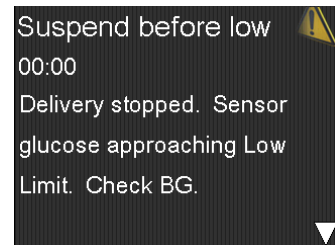

### Suspend before low

When a **Suspend before low** event occurs, an alert appears. Insulin delivery stops. Press  and  to clear the alert. Insulin remains suspended. If **Alert before low** is on, the pump beeps or vibrates every minute until the alert is cleared. If the alert is not cleared in 10 minutes, the pump begins to siren.



**NOTE:** If SG still reaches the low limit, an **Alert on low** alert occurs.

### Suspend on low

When a **Suspend on low** event occurs, an alarm appears. Insulin delivery stops. The pump continues to beep or vibrate every minute for 10 minutes until you press  and  to clear the alarm.



If the **Suspend on low** alarm is not cleared after 10 minutes:

- The pump begins to siren.
- The Medical device alarm appears.

Insulin remains suspended for a maximum of 2 hours.

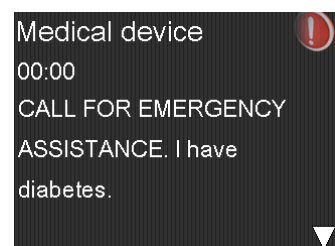

### SmartGuard Suspend Home screen

After the **Suspend before low** or **Suspend on low** message is cleared and insulin delivery stops, the Home screen displays:

- **Suspended before low** or **Suspended on low** appears in a red banner at the bottom of the Home screen.
- The graph on the Home screen is shaded to represent the duration the insulin was suspended.
- The SmartGuard suspend icon flashes.

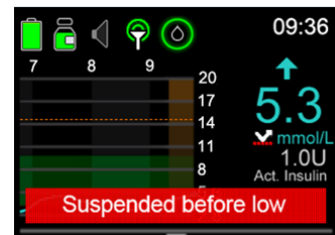

## Resuming basal insulin

There are two ways insulin can be restarted when a SmartGuard suspend feature is active: automatic and manual resume.

### Automatic basal resume

Basal rates automatically resume in the following situations:

- SG values are above the low limit and are trending upward. If you have the **Resume basal alert** on, an alert occurs when basal delivery automatically resumes.
- Insulin has been suspended for the maximum of 2 hours. You always receive a message and are alerted when this occurs.



**NOTE:** Any bolus that was delivering at the time the suspend occurred will not restart when insulin delivery resumes. The basal pattern active at the time the suspend occurred restarts when insulin delivery is resumed. If a temp basal was running and there is still time remaining, the temp basal resumes.

### Manual basal resume

There may be times when you choose to resume basal insulin delivery yourself. Perhaps your healthcare professional has advised you to eat carbohydrates to bring your glucose level up, and does not want insulin to continue to be suspended. You can take these steps to resume basal delivery:

- 1) From the Home screen, press .

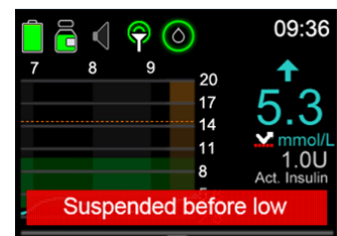

- 2) Select **Resume Basal**.

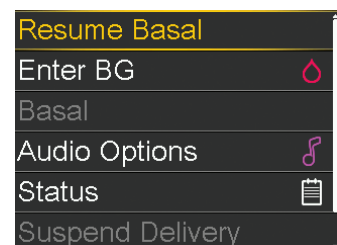

- 3) Select **Resume Basal**.

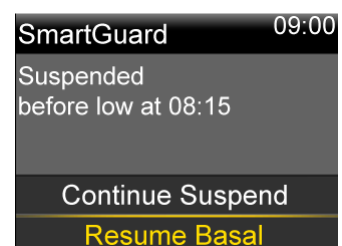

- 4) Select **Yes** to resume basal delivery.

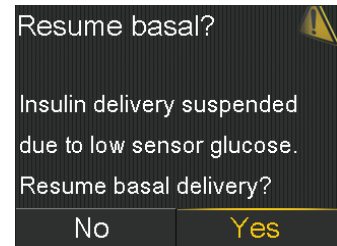

## SmartGuard suspend features unavailable

SmartGuard suspend features are unavailable for a period of time after basal delivery has been resumed following a **Suspend on low** or **Suspend before low** event.

The amount of time the SmartGuard suspend features are unavailable is determined by the following:

Unavailable for 30 minutes if any of the following occurs:

- You have manually resumed the basal insulin.
- Basal insulin is automatically resumed based on the SG.
- You have responded to the alert, and the suspend reaches the 2 hour maximum suspend time.

Unavailable for 4 hours if all of the following occur:

- SG has reached the low limit.
- You did not respond to the alert.
- Basal insulin was suspended for the 2 hour maximum suspend time.



**NOTE:** If the alert is cleared during the 4 hour unavailable period, the SmartGuard suspend feature becomes available after 30 minutes has passed.

## Section 10: Charging and storing the Guardian Link (3) transmitter

**Charge the transmitter before each use.** When the transmitter is charging, a green light flashes on the charger. When charging is complete, the green light on the charger stays on, without flashing, for 15 to 20 seconds and then turns off. You need to charge the transmitter after each sensor use. A fully charged transmitter can be used for a maximum of seven days without recharging. It can take up to two hours to fully recharge.

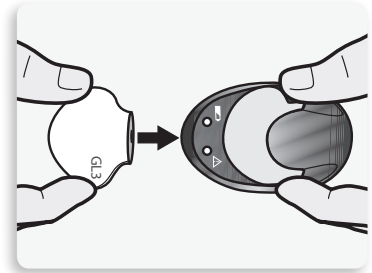

**When you remove the transmitter from the charger, a green light should flash on the transmitter.** This indicates that the transmitter has enough battery power to be connected to the sensor. If you do not see the green light flash on the transmitter, place the transmitter back on the charger until it is fully charged.



**Store the transmitter, charger, and tester in a clean, dry location at room temperature.** Although not required, you may store the transmitter on the charger.



**CAUTION:** The transmitter must be charged every 60 days. Do not store the transmitter on the charger for more than 60 days. Otherwise, the transmitter battery will be permanently damaged. Disconnect and reconnect to the charger to re-charge again before use.

**If you connect your transmitter to the charger and you see no lights on the charger:** Replace the battery in the charger. If there are still no lights on the charger after replacing batteries, the transmitter pins may be damaged. Contact your local Medtronic support representative.

**While charging your transmitter, if you see a flashing red light on the charger:** Replace the battery in the charger.

**While charging your transmitter, if you see a mix of short and long flashing red lights on the charger:** Charge the transmitter for one hour. If the red lights continue to flash, charge the transmitter for eight hours. If the red lights continue to flash after eight hours of charging, please contact your local Medtronic support representative.

**Refer to your Guardian Link (3) transmitter and charger user guides for more information.**

## Section 11: Traveling by air

If you wear a CGM device, it is safe for use on commercial airlines. If questioned by airline personnel about the use of your device, please show them your Medical emergency card.



**IMPORTANT:** Be extra attentive to monitoring your glucose levels while traveling. Always be prepared to respond to changes in glucose if needed.

## Section 12: X-rays, MRI, or CT scan



**WARNING:** Do not expose your pump to MRI equipment, diathermy devices or other devices that generate strong magnetic fields (for example, x-ray, CT scan, or other types of radiation). The strong magnetic fields can cause the devices to malfunction, and result in serious injury. If your pump is exposed to a strong magnetic field, discontinue use and contact your local Medtronic support representative for further assistance. Magnetic fields, and direct contact with magnets, may affect the accurate functioning of your system, which may lead to health risks such as hypoglycemia or hyperglycemia.

Cannula infusion sets such as the MiniMed Quick-set, MiniMed Silhouette and MiniMed Mio can be left in place during the procedure. However, infusion sets that use a needle instead of a cannula to infuse insulin, such as the MiniMed Sure-T, must be removed prior to the procedure.

Do not expose your sensor or transmitter to MRI equipment, diathermy devices, or other devices that generate strong magnetic fields. Exposure to a strong magnetic field has not been evaluated and can cause the device to malfunction, result in serious injury, or be unsafe. If your sensor or transmitter are inadvertently exposed to a strong magnetic field, discontinue use and contact your local Medtronic support representative for further assistance.

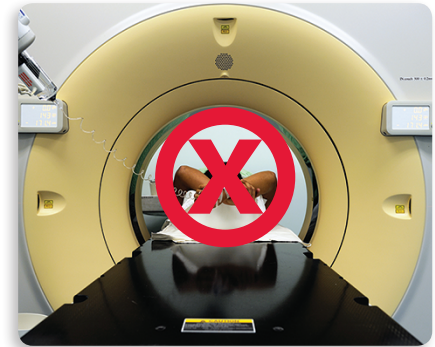



## Training handouts

This section contains handouts that you can use during or after your training.

- The **Quick Reference Guide for Sensor Alerts** provides information about alerts that you might receive.
- The **Quick Reference Guide for Using the One-press Serter with Guardian™ Sensor (3)** reminds you of the steps to take when inserting a new sensor.
- The **Quick Reference Guide for SmartGuard™ Suspend Features** provides further details about the SmartGuard™ suspend features.

Feel free to remove these handouts and keep them in a place where they are easily accessible.

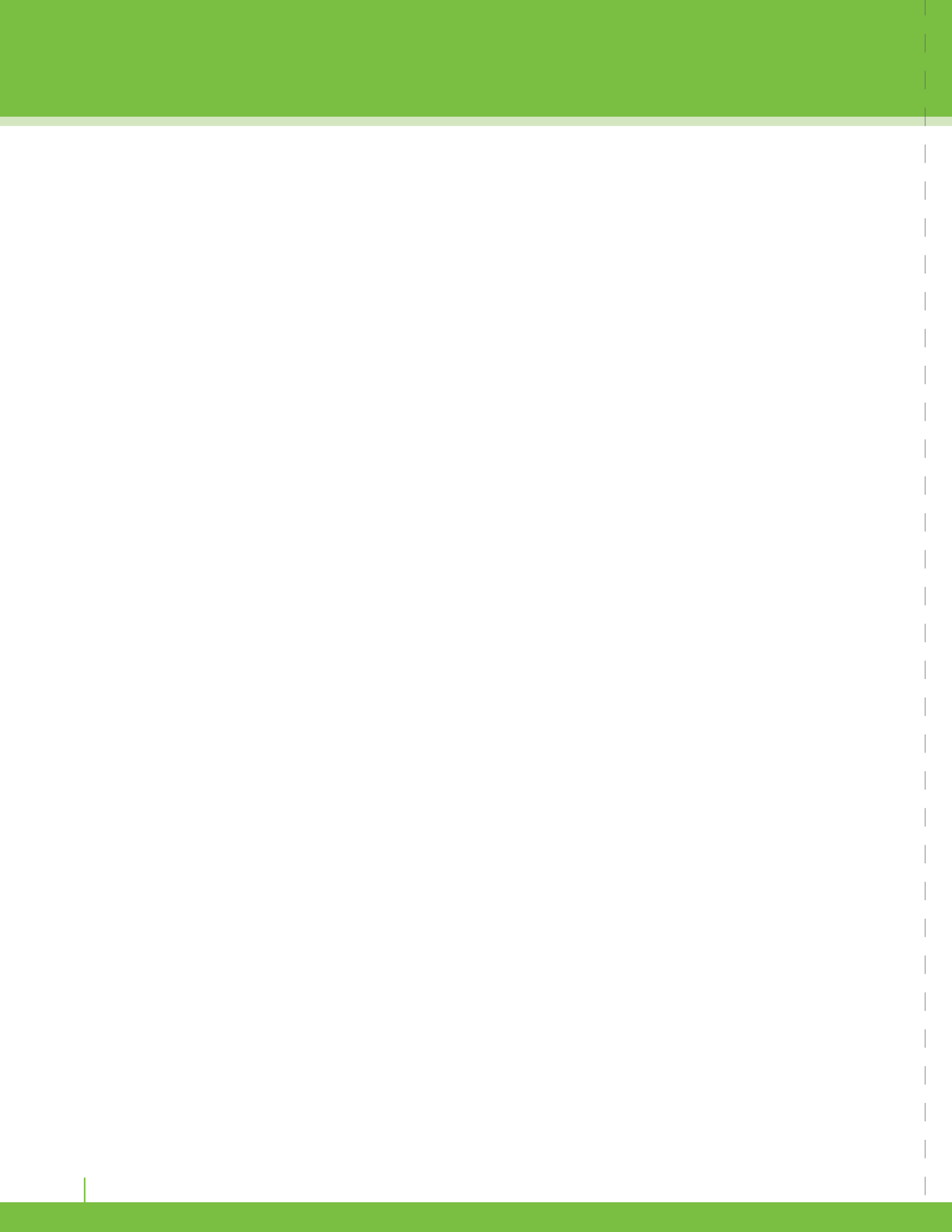

# Quick Reference Guide for Sensor Alerts

## Sensor Alerts

This table shows some of the most common alerts that you may receive when using CGM.



**NOTE:** To silence an alert, press , and then press  on the desired option.

Alert	Reason	Steps to take
Alert on high	The SG value is equal to or higher than the high limit that you set.	Do not treat your glucose based on SG. Confirm it using your BG meter. Treat it if necessary based on instructions from your healthcare professional and continue to monitor.
Alert on low	The SG value is equal to or lower than the low limit that you set.	Do not treat your glucose based on SG. Confirm it using your BG meter. Treat it if necessary based on instructions from your healthcare professional and continue to monitor.
Alert before high	The SG reading is expected to reach the high glucose limit in the length of time you set for the Time before high.	Do not treat your glucose based on SG. Confirm it using your BG meter. Treat it if necessary based on instructions from your healthcare professional and continue to monitor.
Alert before low	The SG reading is expected to reach the low glucose limit within 30 minutes.	Do not treat your glucose based on SG. Confirm it using your BG meter. Treat it if necessary based on instructions from your healthcare professional and continue to monitor.
Rise Alert	The SG reading is increasing at a rate that is equal to or faster than the rate limit that you set.	Do not treat your glucose based on SG. Confirm it using your BG meter. Treat it if necessary based on instructions from your healthcare professional and continue to monitor.

# Quick Reference Guide for Sensor Alerts

<b>Alert</b>	<b>Reason</b>	<b>Steps to take</b>
<b>Calibrate now</b>	A calibration is needed in order to receive SG readings.	Enter BG value into your pump to calibrate.
<b>Lost sensor signal</b>	Communication between pump and transmitter has been lost for 30 minutes during or after warm-up.	Check that the sensor is still inserted in the skin and the transmitter and sensor are still connected. Move your pump closer to your transmitter.
<b>Calibration not accepted</b>	Your system was unable to use the BG meter reading you entered to calibrate your sensor.	In 15 minutes, your pump will prompt you to enter a new BG meter reading for calibration. Wash your hands and dry thoroughly before checking BG.
<b>BG not received</b>	The transmitter was unable to receive the calibration BG reading from the pump.	Move your pump closer to your transmitter and select OK. The pump will try sending the BG again.
<b>Sensor expired</b>	The sensor has reached its maximum usage of 7 full days.	Remove the sensor and follow the instructions for inserting and starting a new sensor.
<b>Sensor updating</b>	The sensor is updating.	Do not calibrate unless notified. This could take up to 3 hours.
<b>Change sensor</b>	You have received two Calibration not accepted alerts in a row.	Remove the sensor and follow the instructions for inserting and starting a new sensor.

# Quick Reference Guide for Using the One-press Sertter with Guardian™ Sensor (3)

## Inserting a new sensor

Wash your hands and clean the insertion site with alcohol.

- 1. Open the sensor package.** Pull the corner of the paper covering to open the sensor package.



- 2a. Hold the sensor by the plastic pedestal.** Remove the sensor with the attached plastic pedestal from the packaging by holding the pedestal only. Place the sensor and the pedestal on a clean, flat surface (such as a table).

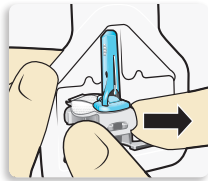

- 2b. Tuck the adhesive tab.** Make sure that the sensor's adhesive tab is tucked under the sensor connector and snaps.

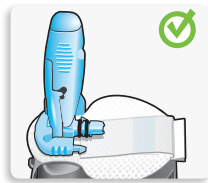

Correct



Incorrect

- 3. Load the sensor into the sertter.** Grip the sertter exactly as shown with your thumb on the thumb print on the sertter. Do not hold the side buttons. Push the sertter down onto the pedestal until the base of the sertter sits flat on the table.

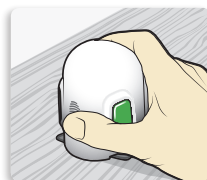
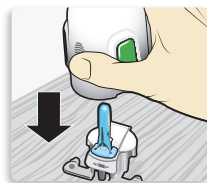

Correct



Incorrect

- 4. Detach the sertter from the pedestal.** To detach the sertter from the pedestal, grip the sertter as shown with your thumb on the thumb print on the sertter. With the other hand, place two fingers on the pedestal arms, and slowly pull the sertter straight up.

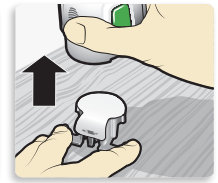
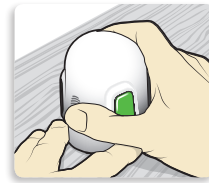
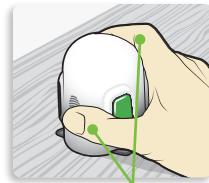

Fingers are NOT holding the side buttons.

**NOTE:** Make sure that the plastic pedestal is firmly on the table before pulling the sertter away.



**CAUTION:** Do not detach the pedestal from the sertter in mid-air as this may damage the sensor.

- 5a. Place the sertter on the body.**

Hold the sertter steadily against the cleaned insertion site, without pushing the sertter too deeply into the skin.



**NOTE:** Failing to hold the sertter securely flat against the body may allow the sertter to spring back after pressing the buttons and result in an improper insertion of the sensor.

- 5b. Insert the sensor.** Press and release the **bump** on both of the buttons at the same time.

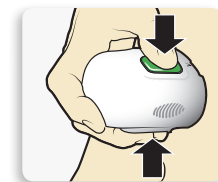

- 5c. Hold the sertter against the body.** Continue holding the sertter against the body for at least five seconds to allow the adhesive to stick to the skin.

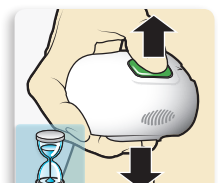

# Quick Reference Guide for Using the One-press Sertter with Guardian™ Sensor (3)

**5d. Remove the sertter from the body.** Slowly pull the sertter away from the skin, making sure the buttons are not pressed.



**6. Remove the needle housing.** Gently hold the base of the sensor against the skin with one hand. With the other hand, hold the needle housing **at the top** and slowly pull it straight away from the sensor. Dispose of the needle housing in a sharps container.

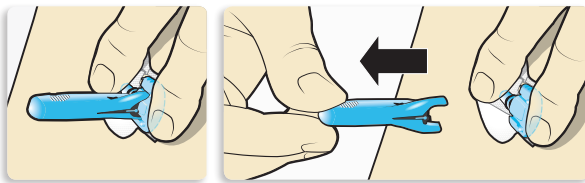

**NOTE:** Apply additional liquid adhesive. You may use an optional adhesive under the adhesive pad prior to removing the liner. Allow the optional adhesive to dry.

**7a. Remove the adhesive pad liner.** Hold the sensor in place and gently remove the adhesive liner from under the adhesive pad.

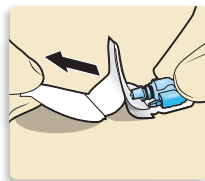
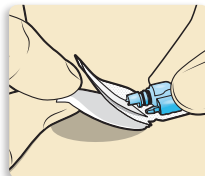

**7b. Press the entire adhesive pad to the skin.** Firmly press the adhesive against the skin and smooth the entire adhesive pad so it sticks to the skin.

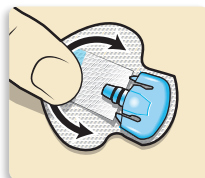

**NOTE:** The Guardian™ Sensor (3) adhesive is sensitive to pressure. Continue applying pressure on the adhesive to ensure that the sensor remains inserted in the skin for up to 7 days of wear.

**8a. Untuck the adhesive tab.** Untuck the adhesive tab from under the sensor connector.

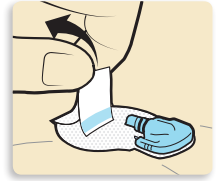

**8b. Straighten the adhesive tab.** Straighten the adhesive tab so it lies flat against the skin, but do not remove the adhesive liner yet.

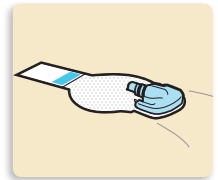

## Taping the sensor

**1. Remove liner 1.**

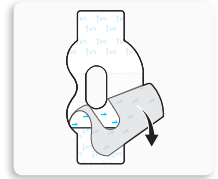

**2. Apply the tape as shown and press it down firmly.**

Both the sensor and the skin are taped.

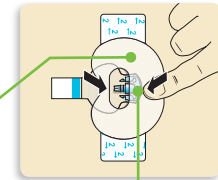

The wide part of the tape covers half of the sensor base.

**3. Remove liner 2 from each side.**

The connector and snaps in the hole of the tape.

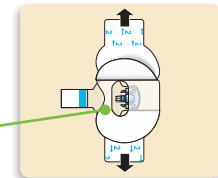

**4. Smooth the tape.**

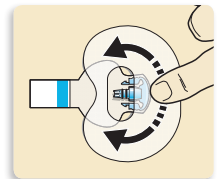

# Quick Reference Guide for Using the One-press Sertter with Guardian™ Sensor (3)

## Connecting your transmitter

1. Connect the transmitter to the sensor.

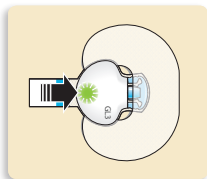

**NOTE:** Wait for the green light on the transmitter to flash. If the green light does not flash, refer to the Troubleshooting section of the transmitter user guide.

2. Remove the liner from the adhesive tab. Cover the transmitter with the adhesive tab.

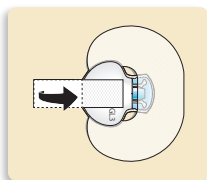

**NOTE:** Do not pull the adhesive tab too tightly.

3. To apply the 2nd tape, remove liner 1.



4. Rotate the 2nd tape and place the tape over the transmitter. Press it down firmly.

The wide part of the tape covers the end of the transmitter and the skin.

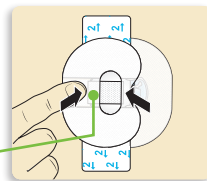

5. Remove liner 2 from each side.

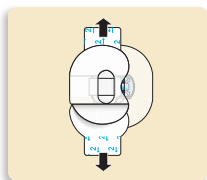

6. Smooth the tape.

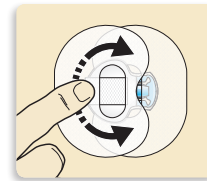

**NOTE:** Check the site regularly. Apply additional tape if the sensor and the transmitter are not secure.

7. This image is an example of oval tape applied correctly.

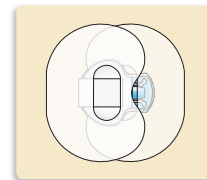

## Starting the sensor

1. Once the **Sensor connected** message appears, press . This typically takes less than a minute, but may take up to 10 minutes.

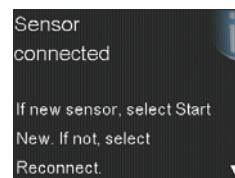

2. Select **Start New Sensor**.

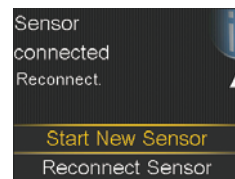

3. The **Sensor warm-up started** message will appear. Press and then to clear.

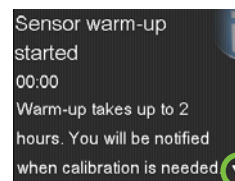

4. **Warm up...** will appear on the Home screen until the sensor is ready for the first calibration.

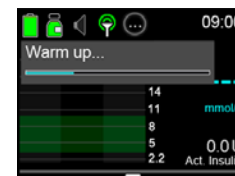

# Quick Reference Guide for Using the One-press Serter with Guardian™ Sensor (3)

## Calibrating

1. Select **Snooze**.

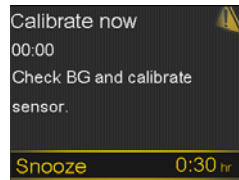

2. The pump will display this screen. Check the BG, and use that BG value to calibrate the sensor. See *Calibration*, on page 32 if you need help calibrating.



3. After a BG for calibration is entered, this screen will display. You will begin receiving SG readings within 5 minutes.



# Quick Reference Guide for SmartGuard™ Suspend Features

The images below show additional details about using the SmartGuard™ suspend features of the MiniMed™ 770G system.



## Suspend on low event:

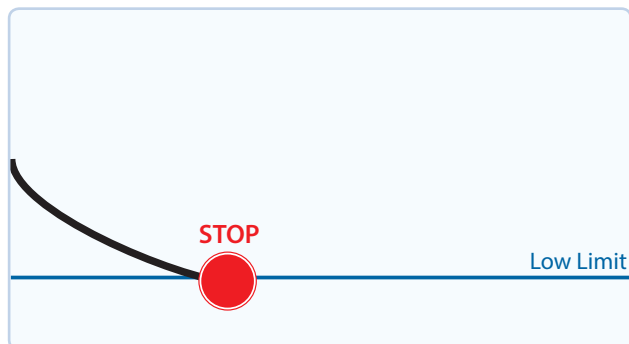

If SG reaches your low limit, insulin delivery will be stopped.

You will always receive a message and alarm when this occurs.

You will have 10 minutes to respond before the pump begins to siren and the Medical device alarm appears.

## Suspend before low event:

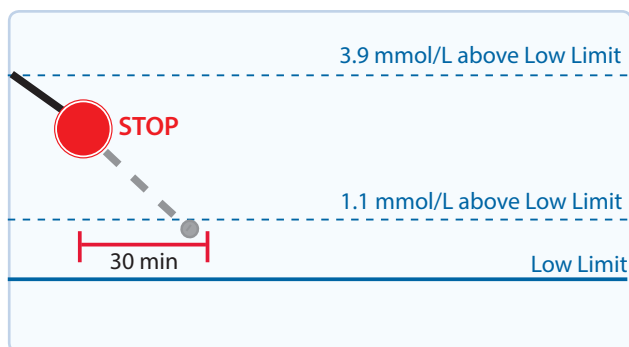

To help keep SG from reaching your low limit, insulin delivery will be stopped in the following situations:

- SG is at or within 3.9 mmol/L above the low limit.
- It is predicted that your SG will approach the low limit in 30 minutes.

If **Alert before low** is on, you will receive an alert when insulin is suspended.

## Alert on low during a Suspend before low event:



If insulin delivery has stopped due to **Suspend before low**, SG may still reach your low limit.

You will always be alerted when this occurs.

You will have 10 minutes to respond before the pump begins to siren and the Medical device alarm appears.

# Quick Reference Guide for SmartGuard™ Suspend Features

Automatic basal resume based on SG value:

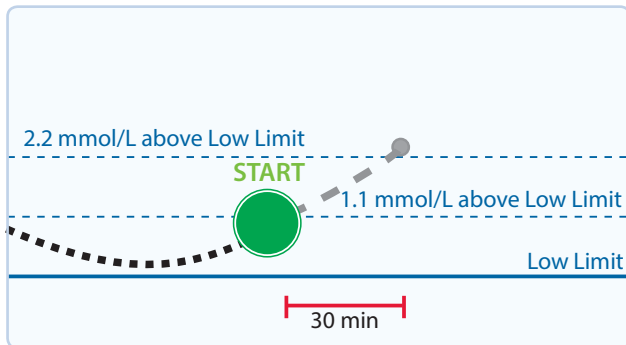

During a **Suspend before low** or **Suspend on low** event, basal insulin automatically resumes in the following situations:

- SG is above the low limit and trending upward.
- Insulin has been suspended by low management for at least 30 minutes.

If **Resume basal alert** is on, you will receive an alert when this occurs. Remember, you can manually resume basal insulin at any time.

Automatic basal resume due to 2 hour maximum suspend:

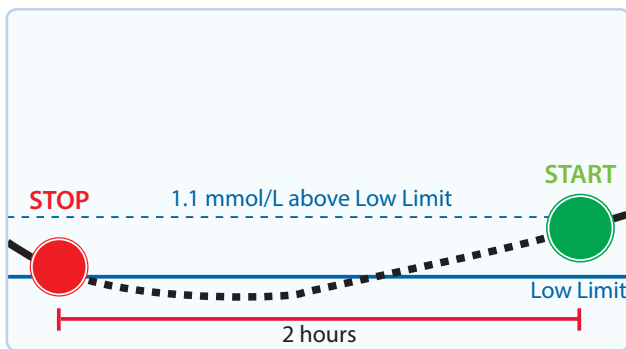

During either a **Suspend before low** or **Suspend on low** event, if basal insulin is not resumed due to SG values, it automatically resumes after 2 hours.

You will always receive an alert when you reach the 2 hour maximum suspend time, even if the **Resume basal alert** is set to Off. Remember, you can manually resume basal insulin at any time.

SmartGuard™ suspend unavailable:

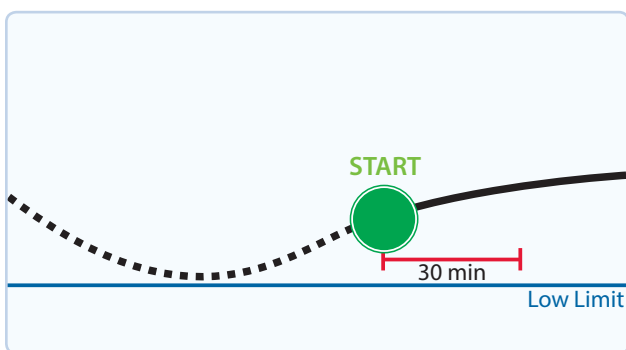

Once basal insulin resumes following either a **Suspend before low** or **Suspend on low** event, there will be a period of time when the SmartGuard™ suspend features are unavailable.

SmartGuard™ suspend features are most often not available for 30 minutes if you respond to the suspend alarm. However, it can be up to 4 hours. See the *MiniMed™ 770G SYSTEM USER GUIDE* for more specific information about the unavailability period of the SmartGuard™ suspend features.



# Medtronic



**Medtronic MiniMed**  
18000 Devonshire Street  
Northridge, CA 91325  
USA  
1 800 646 4633  
+1 818 576 5555

**Medtronic Canada ULC**  
99 Hereford St  
Brampton, ON  
L6Y 0R3  
800 284 4416  
[www.medtronicdiabetes.ca](http://www.medtronicdiabetes.ca)

M000283C021\_1